

# MOOG

## G761/761 Series Installation and Operation Instruction

### Electrohydraulic Servovalve

#### 1. INTRODUCTION

This manual provides instructions and procedures necessary to install, operate and troubleshoot the Moog G761/761 series industrial servovalve. Troubleshooting instructions are outlined so that only the specific component(s) suspected of failure may be identified.

#### 2. OPERATION

The Moog G761/761 series industrial servovalve consists of a polarized electrical torque motor and two stages of hydraulic power amplification. The motor armature extends into the air gaps of the magnetic flux circuit and is supported in this position by a flexure tube member. The flexure tube acts as a seal between the electromagnetic and hydraulic sections of the valve. The two motor coils surround the armature, one on each side of the flexure tube.



The flapper of the first stage hydraulic amplifier is rigidly attached to the midpoint of the armature. The flapper extends through the flexure tube and passes between two nozzles, creating two variable orifices between the nozzle tips and the flapper. The pressure controlled by the flapper and nozzle variable orifice is fed to the end areas of the second stage spool.

The second stage is a conventional 4-way spool design in which output flow from the valve, at a fixed valve pressure drop, is proportional to spool displacement from the null position. A cantilever feedback spring is fixed to the flapper and engages a slot at the center of the spool. Displacement of the spool deflects the feedback spring which creates a force on the armature/flapper assembly.

Input signal induces a magnetic charge in the armature and causes a deflection of the armature and flapper. This assembly pivots about the flexure tube and increases the size of one nozzle orifice and decreases the size of the other.

This action creates a differential pressure from one end of the spool to the other and results in spool displacement. The spool displacement transmits a force in the feedback wire which opposes the original input signal torque. Spool movement continues until the feedback wire force equals the input signal force.

#### ELECTROHYDRAULIC VALVE CUT-AWAY

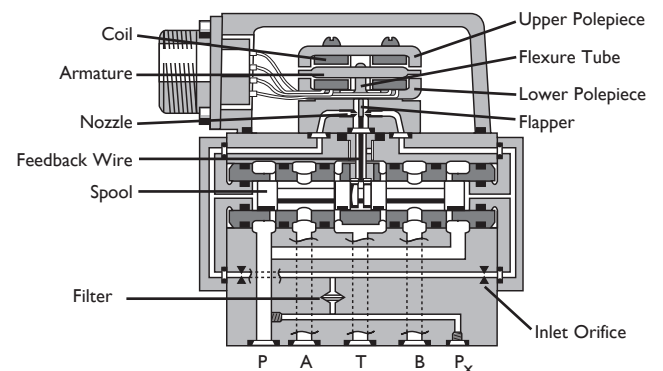

#### CAUTION

DISASSEMBLY, MAINTENANCE, OR REPAIR OTHER THAN IN ACCORDANCE WITH THE INSTRUCTIONS HEREIN OR OTHER SPECIFIC WRITTEN DIRECTIONS FROM MOOG, WILL INVALIDATE MOOG'S OBLIGATIONS UNDER ITS WARRANTY.

Figure 1 Moog Series G761/761

### 3. HYDRAULIC SYSTEM PREPARATION

To prolong servovalve operational life and to reduce hydraulic system maintenance, it is recommended that the hydraulic fluid be kept at a cleanliness level of ISO DIS 4406 Code 16/13 maximum, 14/11 recommended. The most effective filtration scheme incorporates the use of a kidney loop or “off-line” filtration as one of the major filtration components. The filter for the “off-line” filtration scheme should be a  $\beta_{3 \geq 75}$  filter for maximum effectiveness.

Upon system startup and prior to mounting the servovalve, the entire hydraulic system should be purged of built-in contaminating particles by an adequate flushing. The servovalve should be replaced by a flushing manifold and the hydraulic circuit powered up under conditions of fluid temperature and fluid velocity, reasonably simulating normal operating conditions. New system filters are installed during the flushing process whenever the pressure drop across the filter element becomes excessive. The flushing processes should turn over the fluid in the reservoir between fifty to one hundred times.

To maintain a clean hydraulic system, the filters must be replaced on a periodic basis. It is best to monitor the pressure drop across the filter assembly and replace the filter element when the pressure drop becomes excessive. In addition to other filters that are installed in the hydraulic circuit, it is recommended that a large capacity, low pressure  $\beta_{3 \geq 75}$  filter be installed in the return line. This filter will increase the interval between filter element replacement and greatly reduce the system contamination level.

### 4. PILOT STAGE OIL SUPPLY AND NAMEPLATE MODIFICATION (applies to models G761-3001B through G761-3010B)

The Moog G761/761 series industrial servovalve can be configured for pilot stage oil supply through the internal pressure “P” port, or from a separate supply line through the “X” port. Standard configuration is internal pilot operation with a screw and seal washer in the “X” port. This same screw and seal washer must be relocated to the “P” port if an external pilot oil supply source is desired. Refer to Figure 2 for screw and seal washer locations.

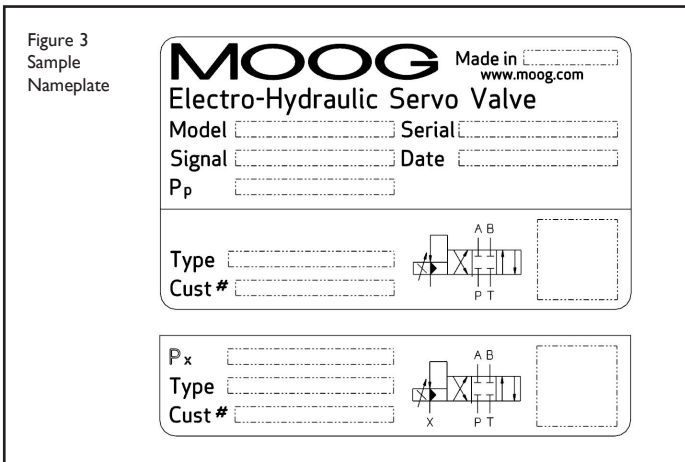
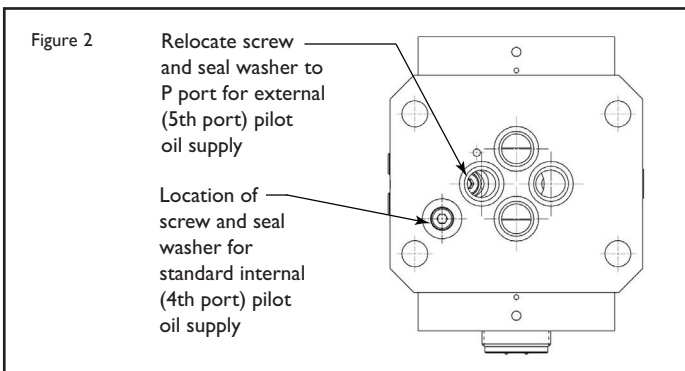

Important:  
Local regulations may require precise hydraulic labeling on components!

Upon valve installation, the nameplate must display the proper hydraulic schematic and typecode (if applicable). The nameplate currently shows internal (4th port) pilot hydraulic schematics and typecode. If a separate pilot supply will be used, please attach the provided lower half label showing external (5th port) information. See Figure 3.

### 5. INSTALLATION

The Moog G761/761 series industrial servovalve may be mounted in any position, provided the servovalve pressure, control and return ports match their respective manifold ports.

The mounting pattern and port locations of the servovalve are shown on Figure 6. The servovalve should be mounted with 5/16-18 x 1.75 inch long, socket head cap screws. Apply a light film of oil to the screw threads and torque to 96 inch pounds. Wire the mating connector for desired coil configuration and polarity. Thread the connector to valve.

### 6. NULL ADJUSTMENT

It is often desirable to adjust the flow null of a servovalve independent of other system parameters. The “mechanical null adjustment” on the Moog G761/761 series servovalve allows at least  $\pm 20\%$  adjustment of flow null.

The “mechanical null adjustor” is an eccentric bushing retainer pin located above the “return” port designation on the valve body (see Figure 4) which, when rotated, provides control of the bushing position. Mechanical feedback elements position the spool relative to the valve body for a given input signal. Therefore, a movement of the bushing relative to the body, changes the flow null.

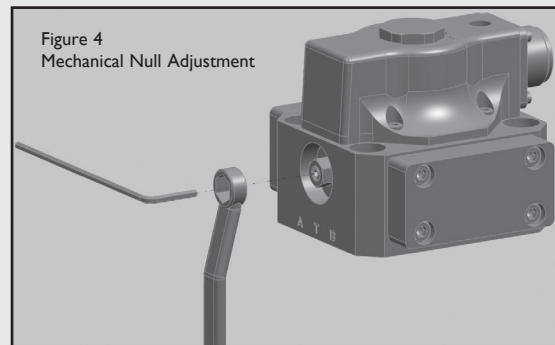

### Mechanical Adjustment Procedure

Using a  $3/8$  inch offset box wrench, loosen the self-locking fitting until the null adjustor pin can be rotated. (This should usually be less than 1/2 turn). DO NOT remove self-locking fitting. Insert a  $3/32$  inch Allen wrench in null adjustor pin. Use the  $3/32$  Allen wrench to rotate the mechanical null adjustor pin to obtain desired flow null. Torque self-locking fitting to 57 inch lbs.

### 7. GENERAL SERVICING RECOMMENDATIONS

- Disconnect the electrical lead to the servovalve.
- Relieve the hydraulic system of residual pressure.
- Remove the servovalve.

## 8. TROUBLESHOOTING CHART

The following troubleshooting chart lists potential troubles encountered, probable causes and remedies.

Potential Trouble	Probable Cause	Remedy
Servo valve does not follow input command signal. (Actuator or components are stationary or creeping slowly).	1. Plugged filter element.	1. Replace filter element.
High threshold. (Jerky, possible oscillatory or "hunting" motion in closed loop system).	1. Plugged filter element.	1. Replace filter element.
Poor response. (Servo valve output lags electrical command signal).	1. Partially plugged filter element.	1. Replace filter element. Check for dirty hydraulic fluid in system.
High Null Bias. (High input current required to maintain hydraulic cylinder or motor stationary).	1. Incorrect null adjustment. 2. Partially plugged filter element.	1. Readjust null. 2. Replace filter element and check for dirty hydraulic fluid in system.

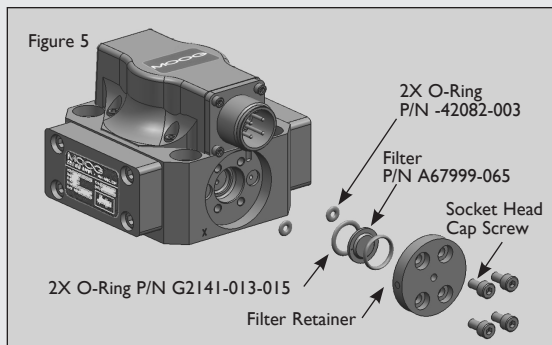

Table I. Replacement Parts

Part Description	Qty.	Part Number
G761/761 Series Filter Replacement Kit	1	B52555RK201K001
O-Ring (1)	2	-42082-003
O-Ring (1)	2	G2141-013-015
Filter Disc (1)	1	A67999-065
Base O-Rings	4	-42082-022
	1	-42082-013

(1) Included in Filter Replacement Kit

## 9. FILTER ASSEMBLY REPLACEMENT

Tools and Equipment

- a. 3mm Allen wrench
  - b. Torque wrench
- a. Remove the four socket head cap screws with 3mm Allen wrench.
  - b. Remove the filter retainer.
  - c. Remove and discard the filter disc.
  - d. Remove and replace the o-ring on the filter retainer and the o-ring in the filter bore.
  - e. Reinstall in reverse order; torque screws to 35-40 in-lbs.

## 10. FUNCTIONAL CHECKOUT AND CENTERING

- a. Install servo valve on hydraulic system or test fixture, but do not connect electrical lead.
- b. Apply required system pressure to servo valve and visually examine for evidence of external leakage. If leakage is present and cannot be rectified by replacing o-rings, remove the discrepant component and return for repair or replacement.  
Note: If the system components are drifting or hardover, adjust the mechanical null of the servo valve.
- c. Connect electrical lead to servo valve and check phasing in accordance with system requirements.

## 11. AUTHORIZED REPAIR FACILITIES

Moog does not authorize any facilities other than Moog or Moog subsidiaries to repair its servo valves. It is recommended you contact Moog at (716) 652-2000 to locate your nearest Moog repair facility. Repair by an independent (unauthorized) repair house will result in voiding the Moog warranty and could lead to performance degradation or safety problems.

# G761/76I SERIES INSTALLATION AND OPERATION INSTRUCTION

## NOTES

### 1 Valve Weight:

Aluminum Body: 2.4 lbs (1.08 kg)

Steel Body: 4.0 lbs (1.81 kg)

### ⚠ Polarity:

A&C (+), B&D (-) produces flow out port B

### 3 Manifold O-Rings:

0.070 (1.78) sect x 0.426 (10.82) I.D.  
(Universal dash No. 13) for P,A, B, T port  
0.070 (1.78) sect x 0.364 (9.25) I.D.  
(Universal dash No. 12) for X port

### 4 Surface:

Surface to which valve is mounted requires  $\sqrt{3}$  (0.8) finish, flat within .001 (0.025) TIR

### ⚠ Electrical Connector:

Mates with MS3106F14S-2S or equivalent

### ⚠ Null Adjust:

Flow out of port B will increase with clockwise rotations of null adjust (3/32 hex key). Flow bias is continually varied for a given port as the null adjust is rotated.

7 Compressed Oil Volume for one control port: 0.229 in<sup>3</sup> (3.75 cm<sup>3</sup>)

8 Suggested Mounting Screws:  
0.312-18 x 1.75 lg (M8 x 45)  
socket head cap screw (4 req'd)

### ⚠ Optional Magnetic Null Adjust

### ⚠ Replaceable Filter Access Cover

⚠ 4X  $\varnothing$  .329 (8.36) thru  $\perp$   $\varnothing$  .531 to depth shown mounting holes.

Dimensions in parenthesis are in millimeters.

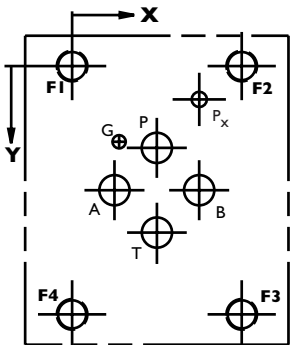
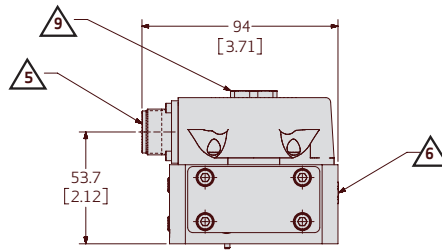
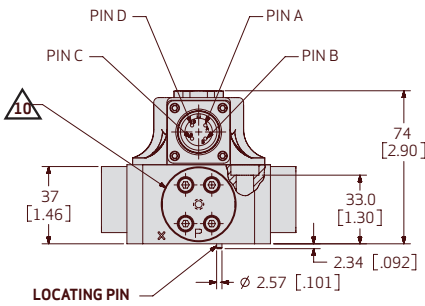
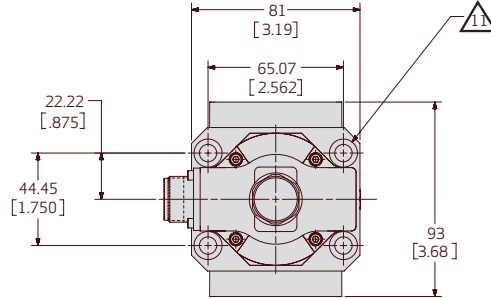

Figure 6

U.S.

	P	A	B	T	X	G	F1	F2	F3	F4
	Ø.32	Ø.32	Ø.32	Ø.32	Ø.2	Ø.14	5/16-18	5/16-18	5/16-18	5/16-18
<b>X</b>	0.87	0.44	1.31	0.87	1.31	0.48	0	1.75	1.75	0
<b>Y</b>	0.84	1.28	1.28	1.72	0.34	0.78	0	0	2.56	2.56

METRIC

	P	A	B	T	X	G	F1	F2	F3	F4
	Ø8.2	Ø8.2	Ø8.2	Ø8.2	Ø5.0	Ø3.5	M8	M8	M8	M8
<b>X</b>	22.2	11.1	33.3	22.2	33.3	12.3	0	44.4	44.4	0
<b>Y</b>	21.4	32.5	32.5	43.6	8.7	19.8	0	0	65.0	65.0

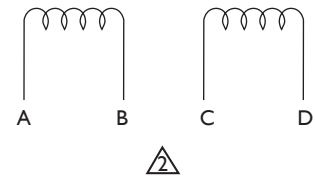

# MOOG

Moog Inc., Industrial Group

[www.moog.com/industrial](http://www.moog.com/industrial)

United States: phone +1 716 652-2000 [info.us@moog.com](mailto:info.us@moog.com)

Europe: phone +49 7031 622 0 [info.germany@moog.com](mailto:info.germany@moog.com)

Asia Pacific: phone +81 45 680 2500 [info.japan@moog.com](mailto:info.japan@moog.com)

For a complete list [www.moog.com/industrial/globallocator](http://www.moog.com/industrial/globallocator)