

I. INTRODUCTION

This manual provides instructions and procedures necessary to install, operate and troubleshoot the Moog Inc. Series 730K or G730K series intrinsic safety protected industrial servovalve. The (G)730K series valves are electrical equipment for hazardous areas requiring intrinsic safety or non-incendive protection. The approved hazardous location markings include:

⊕ I G Ex ia IIC/IIB T4 Ga KEMA 02ATEX1015 X

⊕ II 3G Ex ec II T3 Gc KEMA 02ATEX1016 X

CE 0344 per ATEX directive 2014/34/EU

Ex ia IIB/IIC T4 Ga IECEx KEM 10.0041X

Ex ec IIC T4 Gc IECEx KEM 10.0041X

per IECEx certification scheme.

The G730K servovalves are also approved by FM, CSA, and TIIS for hazardous locations. They are intended for directional, position, velocity, pressure and force control in hydraulic control systems that operate with mineral oil based fluids. Others on request.

2. OPERATION

The Moog Inc. Series (G)730K Electrohydraulic Servovalve consists of a polarized electrical torque motor and two stages of hydraulic power amplification. The motor armature extends into the air gaps of the magnetic flux circuit and is supported in this position by a flexure tube member. The flexure tube acts as a seal between the electromagnetic and hydraulic sections of the valve. The two motor coils surround the armature, one on each side of the flexure tube.

The flapper of the first stage hydraulic amplifier is rigidly attached to the midpoint of the armature. The flapper extends through the flexure tube and passes between two nozzles, creating two variable orifices between the nozzle tips and the flapper. The pressure controlled by the flapper and nozzle variable orifice is fed to the end areas of the second stage spool.

The second stage is a conventional four-way spool design in which output flow from the valve, at a fixed valve pressure drop, is proportional to spool displacement from the null position. A cantilever feedback spring is fixed to the flapper and engages a slot at the center of the spool. Displacement of the spool deflects the feedback spring which creates a force on the armature/flapper assembly.

Input signal induces a magnetic charge in the armature and causes a deflection of the armature and flapper. This assembly pivots about the flexure tube and increases the size of one nozzle orifice and decreases the size of the other.

This action creates a differential pressure from one end of the spool to the other and results in spool displacement. The spool displacement causes a force in the feedback wire which opposes the original input signal torque. Spool movement continues until the feedback wire force equals the input signal force.

CAUTION

DISASSEMBLY, MAINTENANCE, OR REPAIR OTHER THAN IN ACCORDANCE WITH THE INSTRUCTIONS HEREIN OR OTHER SPECIFIC WRITTEN DIRECTIONS FROM MOOG WILL INVALIDATE MOOG'S OBLIGATIONS UNDER ITS WARRANTY AND YIELD THE INTRINSICALLY SAFE PROTECTION PERMIT NULL AND VOID.

MOOG

(G)730K Series Installation and Operation Instruction

Electrohydraulic Servovalve

Intrinsic Safety Protected

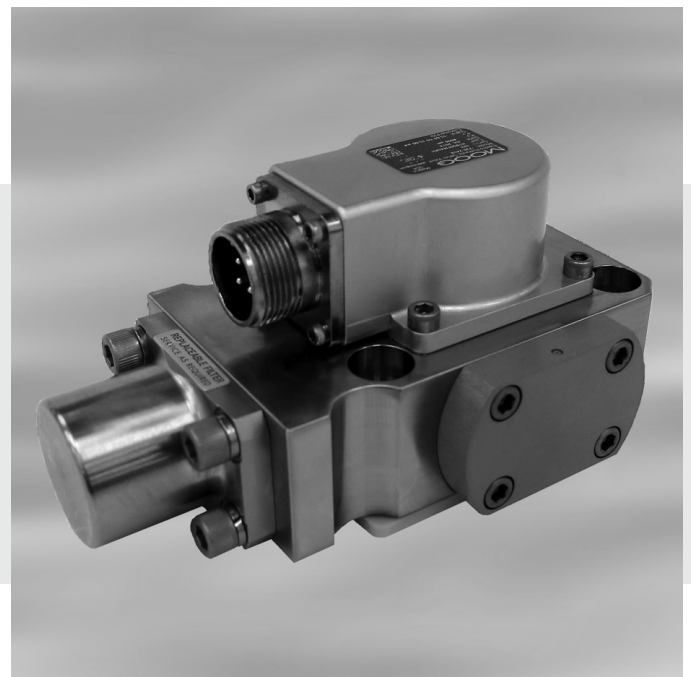

ELECTROHYDRAULIC VALVE CUT-AWAY

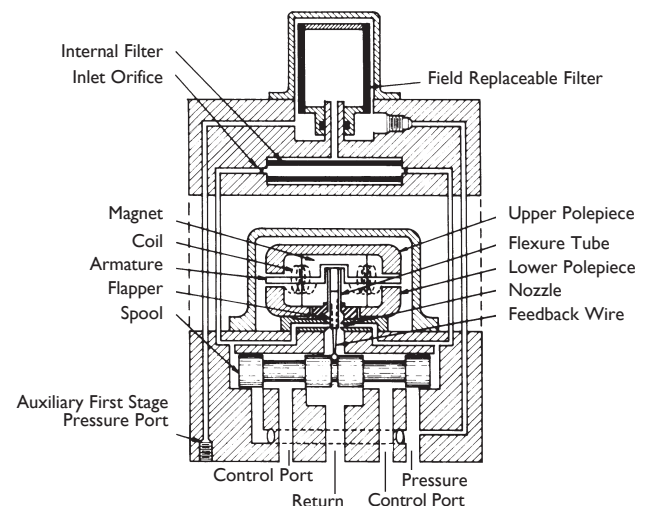

Figure 1 Moog Series (G)730K

3. ELECTRICAL INFORMATION AND INTRINSICALLY SAFE CIRCUIT SAFETY PARAMETERS

- a. A wide choice of coils is available for a variety of rated current requirements. The torque motor coil leads are attached to the connector so external connections can provide series, parallel or single coil operation. The valves are equipped either with an MS type connector or with pigtail leads for electrical wiring. Refer to installation drawings of the specific model for details. Servovalve coils should be driven with current to provide consistency throughout the temperature range.
- b. The (G)730K valves are approved for intrinsically safe protection per EN IEC 60079-0 : 2018, EN 60079-7 : 2015, and EN 60079-11 : 2012 for ATEX, and IEC 60079-0 : 2017, IEC 60079-7 : 2017, and IEC 60079-11 : 2011 for IECEx. The approved safety parameters are listed in the following table for all the coils used by (G)730K series. Coil number is marked on the valve nameplate.

Coil Configuration	Marking	U _i (MAX)	I _i (MAX)
G4220-031 (single, series, parallel)	Ex ia IIB T4	12 V	120 mA
G4220-051/098 (single, series, parallel)	Ex ia IIB T4	12 V	240 mA
G4221-001 G4220-042 (single)	Ex ia IIC T4	16 V	160 mA
G4221-001 G4220-042 (single)	Ex ia IIC T4	24.4 V	85 mA
G4220-031 (single, parallel)	Ex ia IIC T4	30 V	26 mA
G4220-031 (series)	Ex ia IIC T4	30 V	18 mA
G4220-051/098 (single, parallel)	Ex ia IIC T4	30 V	19 mA
G4220-051/098 (series)	Ex ia IIC T4	30 V	12.7 mA
G4220-042 (single)	Ex ia IIC T4	30 V	37 mA
G4220-042 (parallel)	Ex ia IIC T4	30 V	20 mA
G4220-042 (series)	Ex ia IIC T4	30 V	10 mA
G4221-001 (single)	Ex ia IIC T4	30 V	28 mA

- c. The (G)730K valves are approved for non-incendive operation for supply current not to exceed 50 mA dc.
- d. When making electric connections to the valve, appropriate measures must be taken to ensure that locally different earth potential do not result in excessive ground currents. When barriers are required for the hazardous location, hazardous area (field) wiring must meet the requirements of the barrier manufacturer. All barriers must be mounted and installed in compliance with the barrier manufacturer's requirements. Twisted pairs of 18-20 gage wire are recommended. If shielded wire is used, connect shield wire to earth ground only at the barrier strip.

4. SPECIAL CONDITIONS FOR SAFE USE

Because the enclosure of the apparatus is made of aluminum, if it is mounted in an area where the use of category I G apparatus is required, it must be installed such that even in the event of rare incidents, ignition sources due to impact and friction sparks are excluded.

When the electrohydraulic servovalve is used in an application for type of explosion protection intrinsic safety "i", the appropriate box on the data label must be scored. When the electrohydraulic servovalve is used in an application for type of explosion protection "n", the appropriate box on the data label must be scored.

After use in an application for type of explosion protection "n", the servovalve cannot be safely used in an intrinsically safe application.

The screwed cable connector may only be disconnected when the circuit is de-energized or when the location is known to be non-hazardous.

When used at an ambient temperature $\geq 70^{\circ}\text{C}$, heat resistant cable must be used with a continuous operating temperature in accordance with the application.

When the electrohydraulic servovalve is used in type of protection "n" or "ec", the equipment shall only be used in an area of not more than Pollution Degree 2, as defined in IEC 60664-1.

The cable gland shall be installed such that impact is not possible.

When the electrohydraulic servovalve is used in type of protection "n" or "ec", the user shall provide additional clamping of the cable to ensure that pulling is not transmitted to the terminations.

5. HYDRAULIC SYSTEM PREPARATION

To prolong servovalve operational life and to reduce hydraulic system maintenance, it is recommended that the hydraulic fluid be kept at a cleanliness level of ISO DIS 4406 Code 16/13 maximum, 14/11 recommended. The most effective filtration scheme incorporates the use of a kidney loop or "off-line" filtration as one of the major filtration components. The filter for the "off-line" filtration scheme should be a $\beta_3 \geq 75$ filter for maximum effectiveness.

Upon system startup and prior to mounting the servovalve, the entire hydraulic system should be purged of built-in contaminating particles by an adequate flushing. The servovalve should be replaced by a flushing manifold and the hydraulic circuit powered up under conditions of fluid temperature and fluid velocity reasonably simulating normal operating conditions. New system filters are installed during the flushing process whenever the pressure drop across the filter element becomes excessive. The flushing processes should turn over the fluid in the reservoir between fifty to one hundred times.

To maintain a clean hydraulic system, the filters must be replaced on a periodic basis. It is best to monitor the pressure drop across the filter assembly and replace the filter element when the pressure drop becomes excessive. In addition to other filters that are installed in the hydraulic circuit, it is recommended that a large capacity, low pressure $\beta_3 \geq 75$ filter be installed in the return line. This filter will increase the interval between filter element replacements and greatly reduce the system contamination level.

6. INSTALLATION

The Moog (G)730K series industrial servovalve may be mounted in any position, provided the servovalve pressure, control and return ports match respective manifold ports.

The mounting pattern and port location of the servovalve is shown on Figure 4. The servovalve should be mounted with $\frac{3}{16}$ -18 x 1.62 inch long, socket head cap screws. Apply a light film of oil to the screw threads and torque to 96 inch pounds. Wire mating connector for desired coil configuration and polarity. Thread connector to valve.

7. MECHANICAL NULL ADJUSTMENT

It is often desirable to adjust the flow null of a servovalve independent of other system parameters. The "mechanical null adjustment" on the Moog (G)730K series servovalve allows at least $\pm 20\%$ adjustment of flow null. The "mechanical null adjustor" is an eccentric bushing retainer pin located above the return port designation on the valve body (see Figure 2) which, when rotated, provides control of the bushing position. Mechanical feedback elements position the spool relative to the valve body for a given input signal. Therefore, a movement of the bushing relative to the body changes the flow null.

Adjustment Procedure

Using a $\frac{3}{8}$ inch offset box wrench, loosen the self-locking fitting until the null adjustor pin can be rotated. (This should usually be less than $\frac{1}{2}$ turn). DO NOT remove self-locking fitting. Insert a $\frac{3}{32}$ inch Allen wrench in null adjustor pin. Use the $\frac{3}{32}$ Allen wrench to rotate the mechanical null adjustor pin to obtain desired flow null. Torque self-locking fitting to 57 inch lbs.

Note: Clockwise rotation of null adjustor pin produces flow from port P to port 2.

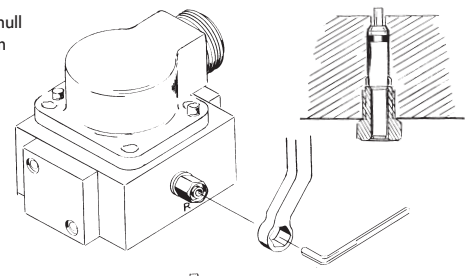

Figure 2
Mechanical Null Adjustment

CONVERSION INSTRUCTIONS FOR EXTERNAL (INTERNAL) PILOT SUPPLY

For external pilot supply operation:

- a. Remove retainer set screw with $\frac{1}{8}$ inch Allen wrench from base of valve.
 - b. Remove plug using a 2-56 screw.
 - c. Remove filter cover and filter cartridge.
 - d. Install plug (O-Ring first) into bore and secure with setscrew.
 - e. Reinstall filter and cover. Torque screws to 85 inch pounds.
- Reverse for changing from external to internal pilot supply.

8. GENERAL SERVICING RECOMMENDATIONS

- Disconnect electrical lead to servovalve.
- Relieve hydraulic system of residual pressure.
- Remove servovalve.

9. TROUBLESHOOTING CHART

The following troubleshooting chart list potential troubles encountered, probable causes and remedies.

Potential Trouble	Probable Cause	Remedy
Servovalve does not follow input command signal. (Actuator or components are stationary or creeping slowly.)	Plugged inlet filter element.	Replace filter element.
High threshold. (Jerky, possible oscillatory or "hunting" motion in closed loop system.)	Plugged filter element.	Replace filter element.
Poor response. (Servovalve output lags electrical command signal).	Partially plugged filter element.	Replace filter element and check for dirty hydraulic fluid in system.
High Null Bias. (High input current required to maintain hydraulic cylinder or motor stationary.)	1. Incorrect null adjustment 2. Partially plugged filter element.	1. Readjust null 2. Replace filter element and check for dirty hydraulic fluid in system.

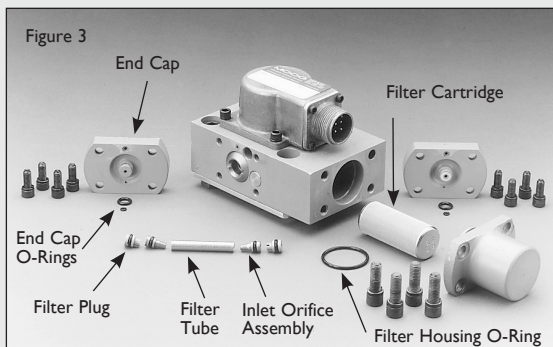

Table I. Replacement Parts

Part Description	Qty.	Part Number
(G)730K Series Filter Replacement Kit	1	B52555RK012K001
Base O-Rings	4	-42082-022
External Pilot Supply O-Ring	1	-42082-013
End Cap - Body O-Rings (I)	2	-42082-001
End Cap - Bushing O-Rings (I)	2	-42082-042
Filter Plug O-Rings (I)	2	-42082-060
Inlet Orifice O-Rings (I)	2	-42082-059
Filter Housing O-Ring (I)	1	-42082-023
Filter Cartridge O-Ring (I)	1	-42082-013
Filter Tube (I)	1	-23020
Filter Cartridge (I)	1	-22050

(I) Included in Filter Replacement Kit.

10. FIELD REPLACEABLE FILTER ASSEMBLY REPLACEMENT

- Remove four socket head cap screws and lockwashers using a $\frac{3}{16}$ inch Allen wrench. Remove filter cover.
- Pull filter cartridge straight out of valve body and inspect for contamination. Discard filter.
- Install o-ring into inner diameter of new filter cartridge. Insert cartridge into bore and over filter port until it bottoms.
- Install filter cover using four screws and lockwashers. Torque to 85 in-lbs.

11. FUNCTIONAL CHECKOUT AND CENTERING

- Install servovalve on hydraulic system or test fixture, but do not connect electrical lead.
- Apply required system pressure to servovalve and visually examine for evidence of external leakage. If leakage is present and cannot be rectified by replacing o-rings, remove the discrepant component and return for repair or replacement.

Note: If the system components are drifting or hardover, adjust the mechanical null of the servovalve.

- Connect electrical lead to servovalve and check phasing in accordance with system requirements.

12. AUTHORIZED REPAIR FACILITIES

If servovalve continues to malfunction after all recommended corrective action procedures are performed, defective valve should be returned to Moog for repair. Moog does not authorize any facilities other than Moog or Moog subsidiaries to repair its servovalves. It is recommended you contact Moog at (716) 652-2000 to locate your closest Moog repair facility. Repair by an independent (unauthorized) repair house will result in voiding the Moog warranty and could lead to performance degradation or safety problems.

13. DECLARATION OF MANUFACTURER

An EU Declaration of Conformity according to Council Directive 2014/34/EU is supplied with each servovalve.

(G)730K SERIES INSTALLATION AND OPERATION INSTRUCTION

NOTES

1 Fluid:

Industrial type petroleum base hydraulic fluid, maintained to ISO DIS 4406 Code 14/11 recommended.

2 Operating Temperature Range:

-40°F [-40°C] to +275°F [+135°C] unless otherwise specified on nameplate.

3 Valve Phasing:

Flow out port B results when Series coils: B & C connected, A+, D-; Parallel coils: A & C connected, B & D connected; Single coil: A+, B-, or C+, D-.

4 Ports:

P, R, A & B: 0.312 diam. co'bored nominally .562 diam. x .055 deep accepts MS 28775-013 o-ring. Aux. pressure port .213 diam. co'bored nominal .498 diam. x .055 deep accepts MS 28775-012 o-ring.

5 Surface:

Surface to which valve is mounted requires \sqrt{V} finish, flat within .002 [0.05] TIR.

6 Null Adjust:

Flow out port 2 results with clockwise rotation of null adjust screw.

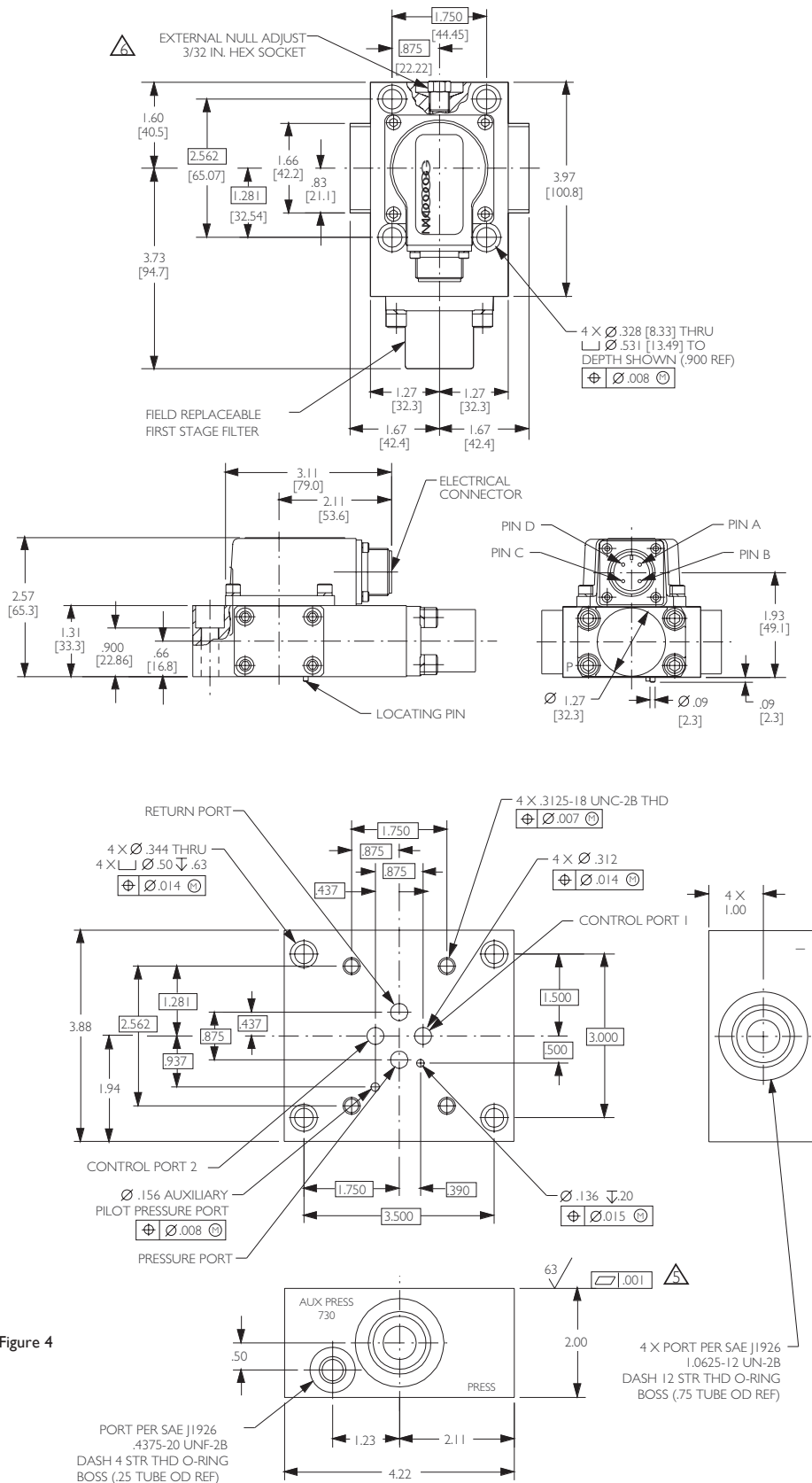
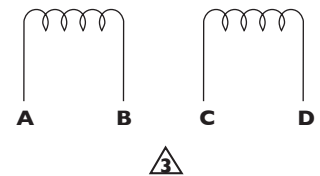

Figure 4

TYPICAL WIRING SCHEMATIC



CERTIFICATION CONTROLLED RELATED DOCUMENT
 THIS INSTALLATION INSTRUCTION IS CERTIFICATION CONTROLLED.
 REVISION SHALL BE APPROVED BY THE MOOG ICD EX/ATEX
 AUTHORIZED PERSON AND MAY REQUIRE APPROVAL BY THE ATEX
 NOTIFIED BODY.
 APPLICABLE CERTIFICATE(S):
 KEMA 02ATEX1015 X
 KEMA 02ATEX1016 X

The products described herein are subject to change at any time without notice, including, but not limited to, product features, specifications, and designs.

MOOG

Industrial Controls Division

Moog Inc., East Aurora, NY 14052-0018

Telephone: 716/652-2000

Fax: 716/687-7910

Toll Free: 1-800-272-MOOG

www.moog.com

TJW/PDF RevE, January 2023, Id. CDS6755