

**MOOG**

**DBM 04**

**Installation**

**Manual**



# TABLE OF CONTENTS

<b>SECTION 1</b> <b>Description</b>	description	I - 9
	electrical data	9
	dimensions	12
	component identification	14
	system grounding	15
	options	16
	rating plate	16
<b>SECTION 2</b> <b>Installation</b>	fuses	II - 2
	soft start	2
	transformers	3
	thermal sizing of cabinet	3
	recovery circuit	4
	fan assembly	5
	wire type	6
	power supply - wiring	10
	power supply - led's	14
	power supply - internal card jumpers	14
	module wiring	19
	resolver wiring	22
	motor phases wiring	29
	module - leds	32
	personality card jumpers	33
	potentiometer/button	35
	input/output characteristics	35
	serial link connection	36
	starting sequence	41
	resolver to encoder option	46
mechanical brake	48	
module replacement	49	
<b>SECTION 3</b> <b>EMC</b>	European Directive	III - 1
	filtering	1
	wiring and grounding	4
	recovery resistor	6
	screening	7
	safety aspects	7

**This page intentionally blank**

# Accident Protection

The safety instructions provided in this Manual are included to prevent injury to personnel (**WARNINGS**) or damage to equipment (**CAUTIONS**).

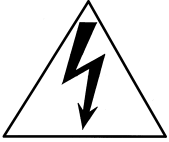

**WARNING:** L+ and L- pins and Bus Bar's can have voltage  $\geq 810V_{dc}$  even after switching off (capacitive voltage).  
High Voltage - Discharge Time approx. 6 Minutes.

**WARNING:** High Voltage. The recovery resistor is connected to the Bus Bar's and can have voltage  $\geq 810V_{dc}$ .

**WARNING:** do not touch recovery resistor during operation to avoid scalds.

**CAUTION:** make sure that the correct input voltage, 400V or 460V, has been set.

**CAUTION:** it is recommended to disconnect the drive and the EMC filters to carry out the AC Voltage Tests of EN 60204-1 (1997), par.19.4, in order to not damage the Y-type capacitors between phases and ground. Moreover the DC voltage dielectric test required by EN 50178 (1997), product family standard, has been carried out in factory as a routine test. The DC Insulation Resistance Tests of EN 60204-1 (1997), par.19.3, may be carried out without disconnecting the drive and the EMC filters.

**CAUTION:** when required for an emergency stop, opening U2-V2-W2 pins and closing motor phases to resistors, must be preceded by disabling the axis. The delay time must be at least 30 ms.

**CAUTION:** in case of repetitive switching on and off, wait 1 minute between off and on.

**CAUTION:** it is recommended to close the WP jumper on the Personality Card at the end of installation and setup.

**CAUTION:** do not exceed the tightening torque of the table (but see proper data sheets for the tightening torque of input capacitors and power modules and see Section 2 of this Manual for the tightening torque of terminal blocks)

Screw Thread	Tightening torque	
	[Nm]	[lb in]
M3	1.00	8.85
M4	3.00	26.55
M5	6.00	53.10
M6	8.00	70.80
M8	20.0	177.0

**EC DECLARATION OF CONFORMITY**

The undersigned, representing the following manufacturer

<b>Moog Italiana S.r.l., Electric Division</b>
<b>Via Avosso 94, Casella (Genova), ITALY</b>

herewith declares that the products

Complete Drive Modules series: BRD-4S, DBC III, DBS, DS2000, PDBS Basic Drive Modules series: BRM-4S, DBM 03, DBM 033, DBM 04, Feeding sections series: ADR, BRM-P1, BRM-P2, DBM 03-PS, DBM 033-PS, DBM 04-PS Motor groups series: FAE F/ K/ N/ T/ W, FAS F/ K/ N/ T/ W, FC
--

are in conformity with the provisions of the following EC directives  
(including all applicable amendments)

ref. n°	title
73/23/EEC	Low Voltage Directive
89/336/EEC	EMC Directive

and that the following harmonized standards, or parts thereof, have been applied

nr	issue	title	parts
EN 60034-1	1998	Rotating electrical machines. Part 1: Rating and performance	
EN 60034-6	1993	Rotating electrical machines. Part 6: IC Code	
EN 60034-7	1993	Rotating electrical machines. Part 7: IM code	
CEI EN 60204-1	1993	Safety of Machinery. Electrical Equipment of machines. Part 1: General requirements	par. 6.2.3, 20.3, 20.4
EN 60529	1991	IP code	
CEI EN 61800-3	1996	Adjustable speed electrical power drive systems. Part 3: EMC product standard including specific test methods	par. 4, 5.3.2, 6.3.2
EN 61800-3 /A11	2000	Amendment A11	

**Other references or information required by the applicable EC directives:**

The conformity of products is subjected to the installation of filters and to the procedures included in the proper "Installation Manual". The user has the primary EMC responsibility in following the recommendations of the manufacturer.

**Last two digits of the year in which the CE marking was affixed: 97**

Casella, 2/Nov/2000

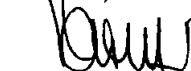

Walter Tettamanti  
**GENERAL MANAGER**

# CE Requirements

- **Cautionary Marking.** See Accident Protection page.
- **Protection against electric shock.** Electronic Equipment intended for installation in closed electrical operating areas kept locked. The lock shall be only opened by authorized person and the access only allowed to skilled persons whilst energized. Where the equipment requires manual intervention, 412.2.1 of HD 384.4.41 S2 shall be consulted.
- **Fixed connection for protection.** The equipment may have a continuous leakage current of more than a.c. 3.5 mA or d.c. 10 mA in normal use and a fixed ground connection is required for protection.
- **RCD.** A d.c. component can occur in the fault current in the event of a fault connection to earth. Only a residual-current-operated protective device (RCD) of Type B is allowed. When the protection in installations with regard to indirect contact is achieved by means of an RCD, their appropriate function/combination shall be verified.
- **Climatic Conditions.** Equipment intended to operate within its performance specification over the range of Class 3K3, as defined in table 1 of EN 60721-3-1, EN 60721-3-2, EN 60721-3-3, EN 60721-3-4, partly modified.
- **Pollution Degree 2 Installation** - The equipment shall be placed in a pollution degree 2 environment, where normally only non-conductive pollution occurs. Occasionally, however, a temporary conductivity caused by condensation is to be expected, when the electronic equipment is out of operation.
- **EMC Requirements.** The installer of the equipment is responsible for ensuring compliance with the EMC standards that apply where the equipment is to be used. Product conformity is subjected to filters installation and to recommended procedures, as from Section 3 of this Manual.
- **Second Environment (EMC).** Equipment intended to be connected to an industrial low-voltage power supply network, or public network which does not supply buildings used for domestic purposes (second environment, according to EMC Standards). It is not intended to be used on a low-voltage public network which supplies domestic premises (first environment). Radio frequency interference is expected if used on such a network.
- **Recovery Resistor Cable.** Shielding of the external recovery resistor cable, provided in kit for test purposes, is recommended for ensuring compliance with the EMC standards.

**UL International Italia S.r.l.**

Centro Direzionale Colleoni - Palazzo Andromeda 3  
I - 20041 Agrate Brianza (MI)  
Tel: +39 039 6057937  
Fax: +39 039 651946  
E-mail: info@it.ul.com

Agrate Brianza, June 18<sup>th</sup>, 2001

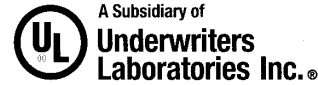

Spett.le

MOOG Italiana S.r.l.

Electric Division

Via Avosso, 94

I - 16015 Casella (Genova) - Italy

Attn.: Mr. Daniele Rolla

**Subject : Ind. Cont. Eq., Component - Power Conversion Equipment (NMMS2) (NMMS8)  
Open Type, Brushless Motor Servo-Drives : "DBM 04 Series"  
New Power Supply "PS-Universal" - Drive Models Revision**

**Ref. : File E194181 Vol. 2, Sec. 1 - Project 01ME07525 - Report Revision**

**NOTICE OF AUTHORIZATION TO APPLY THE UL RECOGNITION MARK  
AND UL CANADIAN RECOGNITION MARK**

This letter is sent on behalf of Underwriters Laboratories Inc. pursuant to the Corporate Services Agreement between Underwriters Laboratories Inc. and UL International Italia Srl.

We find that the product is eligible for Recognition and Follow-Up Service.

This letter temporarily supplements the UL Follow-Up Services Inspection Procedure, and serves as authorization to apply the UL Recognition Mark and Recognition Mark For Canada to the above products.

To provide the manufacturer with the intended authorization to use the UL Recognition Mark and Recognition Mark For Canada you, the Applicant, must send a copy of this Notice to each manufacturing location covered by the UL Follow-Up Service Procedure, File E194181, Vol. 2, Sec. 1.

This authorization is effective only for 90 days from the date of this Notice. Records covering your products are now being prepared and will be sent to you in the near future.

Products produced which bear the UL Recognition Mark and Recognition Mark for Canada shall be identical to those, which were evaluated by UL and are found to comply with UL's requirements. If changes in construction are discovered, authorization to use the UL Recognition Mark and Recognition Mark For Canada may be withdrawn and the products that bear the UL Mark may have to be revised (in the field or at the manufacturer's facility) to bring them into compliance with UL's requirements.

Within Canada, there are federal and local statutes and regulations, such as the Consumer Packaging and Labeling Act, requiring the use of bilingual product markings on products intended for the Canadian market. It is the responsibility of the manufacturer (or distributor) to comply with this law. The UL Follow-Up Service Procedures will only include the English version of the markings.

If we can be of assistance, please do not hesitate to contact the undersigned.

Very truly yours,

Giuseppe Redaelli  
Engineering Services  
UL International Italia Srl

REVIEWED BY:

Kevin Connelly  
Engineering Services  
UL International Germany GmbH



# UL Requirements

- These Brushless Servo-Drives shall be assembled with the guidelines specified in this Manual. Only the configurations with the components tested and described in the UL Report, file E194181, Vol.2, Sec.1, Issue date 03-28-01 and following Revisions can bear the Recognized Component (R/C) Mark. Each assembled configuration shall be evaluated in the UL Listed end-use application.
- The Component – Power Conversion Equipment “DBM 04 Series” is considered UL Recognized in the complete configurations after the assembly of the three main parts of the Drive, that is the Power Supply, the Modules and the Fan Assembly. The Marking, including the R/C Mark and the Drive Model No., shall consider the equipment in its complete configuration.
- These drives shall be used within their ratings, as specified in the marking of the equipment. In particular:
  - rated input voltage, input current, system duty cycle, auxiliary input voltage, auxiliary input power, fan input voltage, fan input power on the label affixed on the fan assembly
  - rated axis continuous output current, axis max output current, module duty cycle on the label affixed on the module
- **Cautionary Marking.** See Accident Protection page.
- **Duty Cycle.** The maximum continuous Drive output current shall be limited to 65 A and to the Maximum Module Current, due to the rated current of the Power Supply and of the Module. According to this reason, the Drive shall be used with a Duty Cycle, as specified in the marking of the equipment.
- **Surrounding Air Temperature** - *“Maximum Surrounding Air Temperature 40°C”*. In the final installation considerations shall be given for the need of repeating Temperature test if the unit is mounted with a different Surrounding Air conditions.
- **Pollution degree 2 Installation** - The drive must be placed in a pollution degree 2 Environment.
- **Environmental designation** - *“Open Type Equipment”*.
- **Short Circuit Ratings.** *“Equipment suitable for use on a circuit capable of delivering not more than 5000 rms Symmetrical Amperes, 460 V ac +10% maximum”*
- **Branch Circuit Protection.** The Branch Circuit Protection for Short Circuit shall be provided in the end-use applications by external R/C Fuses (JFHR2), manufactured by Bussmann Div Cooper (UK) Ltd, Semiconductor fuse type, Mod.No. 160 FEE, rated 160 A, 660 Vac, 200 kA A.I.C.

- **Overspeed Protection.** The Power Conversion Equipment is incorporating an Overspeed Protection. See MV command in the User's Manual.
- **Overvoltage Control.** In the equipment the Overvoltage is controlled by a Transient Suppressive device, with 1500 V Clamping Voltage and min 120 J (10x1000 us or 2 ms) Energy Handling Capability. See also "Bus not normal" protection in the User's Manual.
- **Overload Protection.** The equipment does not incorporate internal overload protection for the motor load. The drive is intended to be used with motors that must have integral thermal protection through a PTC. The overtemperature fault of the drive will trip when the PTC reaches 1.2 k $\Omega$ . See J4-J5-J6 connectors in Section 2 of this Manual for wiring.
- **Over-Current Protection.** The drive is provided with a current limiting circuitry. See IL and IT commands in the User's Manual.
- **Factory Wiring.** These equipments are suitable only for Factory Wiring only, that is the Terminal Blocks and the Connectors for Power Connection Wiring are not suitable for Field Wiring. In particular the DC-Bus Terminal Blocks for the Power Supply and Modules Interconnection shall be usable only with the DC-Bus Interconnection Cables provided by the manufacturer.
- **Wiring.** Wiring shall be made by stranded and/or solid, copper (Cu), 60/75°C (140/167°F) conductor only, and, for terminal blocks, the tightening torque values specified in Section 2 of this Manual shall be applied. These requirements do not pertain to control circuit terminals.
- **Wiring of Recovery Resistor.** The Dynamic Brake Unit Recovery Resistor shall have the connection wiring made with R/C (AVLV2) or insulated with R/C (YDPU2) or R/C (UZCW2) in the end-use installation.

# SECTION 1 - DESCRIPTION

## 1.1 Description

DBM04 four quadrant servodrives provide unrivaled compactness and flexibility through the integration of three axes in a single module.

A power supply is connected directly to the power distribution line at 400 or 460V and can supply up to 6 modules (18 axes). The result is a very suitable solution for all multi-axis applications like machine tools, robotics, packaging, special material working (wood, plastics, glass, rubber, leather, paper).

A microprocessor based structure allows high servo performances with FASTACT and FC servomotors all equipped with a resolver feedback. Drive tuning and configuration are performed via digital parameters (not potentiometers) and stored in non-volatile memory (EEPROM).

Drive set up is possible via a keypad or PC, therefore simplifying installation and providing easy fault diagnosis.

General features:

- digital speed loop
- sinusoidal current waveform
- SMD technology with boards automatically assembled and tested
- automatic Resolver to Digital (R/D) resolution switching (from 16 to 10 bit) to achieve high motion accuracy in the whole speed range (from 0 to 10000 RPM).
- up to 99 axis system configuration
- 10 kHz switching frequency
- operating temperature: 0 to +40°C (exceeding Class 3K3)
- relative humidity: 5% to 85% (no condensation, no formation of ice)
- air pressure: 86 kPa to 106 kPa
- storage temperature: -25 to +55°C (Class 1K4)
- transportation temperature: -25 to +70°C (Class 2K3)
- immunity to vibration: Class V.H.2 according to HD 413.3 S1 (1987)
- maximum case depth of 310 mm

## 1.2 Electrical Data

### PS-Standard Power Supply

- 3-phase power input voltage: 400 or 460 Vac (selectable via switch),  $\pm 10\%$ , 50/60 Hz
- 1-phase auxiliary input voltage: 110 or 230 Vac (selectable via jumper),  $\pm 10\%$ , 50/60 Hz
- input current: 65 A
- output current: see tab. 1.1
- max number of modules supplied: 4

### **PS-6M Power Supply (Standard Plus)**

- 3-phase power input voltage: 400 or 460 Vac (selectable via switch),  $\pm 10\%$ , 50/60 Hz
- 1-phase auxiliary input voltage: 110 or 230 Vac (selectable via jumper),  $\pm 10\%$ , 50/60 Hz
- input current: 65 A
- output current: see tab. 1.1
- max number of modules supplied: 6

### **PS-Standalone Power Supply**

- 3-phase power input voltage: 400 Vac or 460 Vac (set in factory),  $\pm 10\%$ , 50/60 Hz
- 1-phase auxiliary input voltage (for data saving): 230 Vac,  $\pm 10\%$ , 50/60 Hz
- input current: 65 A
- output current: see tab. 1.1
- max number of modules supplied: 4

### **PS-120 Power Supply (Powered Standalone)**

- 3-phase power input voltage: 400 Vac or 460 Vac (set in factory),  $\pm 10\%$ , 50/60 Hz
- 1-phase auxiliary input voltage (for data saving): 230 Vac,  $\pm 10\%$ , 50/60 Hz
- input current: 120 A
- output current: see tab. 1.1
- max number of modules supplied: 4

### **PS-U Power Supply (Special Standalone)**

- 3-phase power input voltage: 400 to 460 Vac,  $\pm 10\%$ , 50/60 Hz
- auxiliary input voltage (for data saving): 24 Vdc,  $\pm 10\%$
- input current: 65 A
- output current: see tab. 1.1
- max number of modules supplied: 4

### **DBM 04 Module**

- BUS BAR rated voltage: 540 Vdc (with 400 Vac) or 620 Vdc (with 460 Vac)
- three-phase output voltage: 325 Vac (with 400 Vac) or 375 Vac (with 460 Vac)
- output current: see tab. 1.1

### **DBM 04 Fan Assembly**

- input voltage: 230 Vac or 115 Vac,  $+6\%/-10\%$ , 50/60 Hz, or 24 Vdc,  $\pm 4\%$
- input power: see tab. 2.1

## TAB. 1.1 - OUTPUT CURRENT

STANDARD MODULES (see tab.2.16 for the other possible configurations)

Model	Output Current									Width (mm)	Weight (kg)
	Axis 1			Axis 2			Axis 3				
	Rated	Max		Rated	Max		Rated	Max			
	(Arms)	(Arms)	(A)	(Arms)	(Arms)	(A)	(Arms)	(Arms)	(A)		
DBM 04 3-3	3	6.4	9	3	6.4	9	-	-	-	120	8
DBM 04 6-6	6	10.6	15	6	10.6	15	-	-	-	120	8
DBM 04 8-8	8	15.6	22	8	15.6	22	-	-	-	120	8
DBM 04 15-15	15	29.7	42	15	29.7	42	-	-	-	120	9
DBM 04 25-25	25	49.5	70	25	49.5	70	-	-	-	180	13
DBM 04 35-35*	35	63.6	90	35	63.6	90	-	-	-	270	18
DBM 04 3-3-3	3	6.4	9	3	6.4	9	3	6.4	9	120	9
DBM 04 6-6-6	6	10.6	15	6	10.6	15	6	10.6	15	120	9
DBM 04 8-8-8	8	15.6	22	8	15.6	22	8	15.6	22	120	9
DBM 04 15-15-15	15	29.7	42	15	29.7	42	15	29.7	42	180	14

\* a duty cycle of 92% applies

### POWER SUPPLY - 400/460 Vac

Model	Current			Auxiliary Input Voltage (V)	Width (mm)	Weight (kg)
	Output Rated	Output Max	Braking			
	(A)	(A)	(A)			
PS-Standard Power Supply	65	100	100	110/230 Vac	120	13
PS-6M Power Supply (Standard Plus)	65	100	100	110/230 Vac	120	13
PS-Standalone Power Supply	65	100	100	230 Vac*	120	13
PS-120 Power Supply (Powered Standalone)	120	280	175	230 Vac*	180	20
PS-U Power Supply (Special Standalone)	65	100	100	24 Vdc*	120	13

\* this is not necessary for normal duty but only for data saving

### EXPANSIONS

An external expansion module should be used for some configurations, including an axis rated over 35A. This is due to thermal constrictions.

Available expansions modules are shown in the table. To specify an expansion module, please replace the third axis rating number with E, this ensures that the drive is configured for use with an expansion module (e.g. DBM 04 15-15-E).

Model	Output Current			Width (mm)	Weight (kg)
	Rated	Max			
	(Arms)	(A)	(A)		
EBM 04 50/140	50	99	140	270	18
EBM 04 60/180	60	127	180	270	18

### 1.3 Dimensions

Fig. 1.1 and 1.2 (dimensions in mm) show the drilling jig between power supply and drive module. The modules must be mounted vertically, with the fan housing at the bottom. Leave a clear space of at least 50 cm (19.7 in) over and under the system for air circulation.

**Fig. 1.1 Front View (Drill For M5 Screws)**

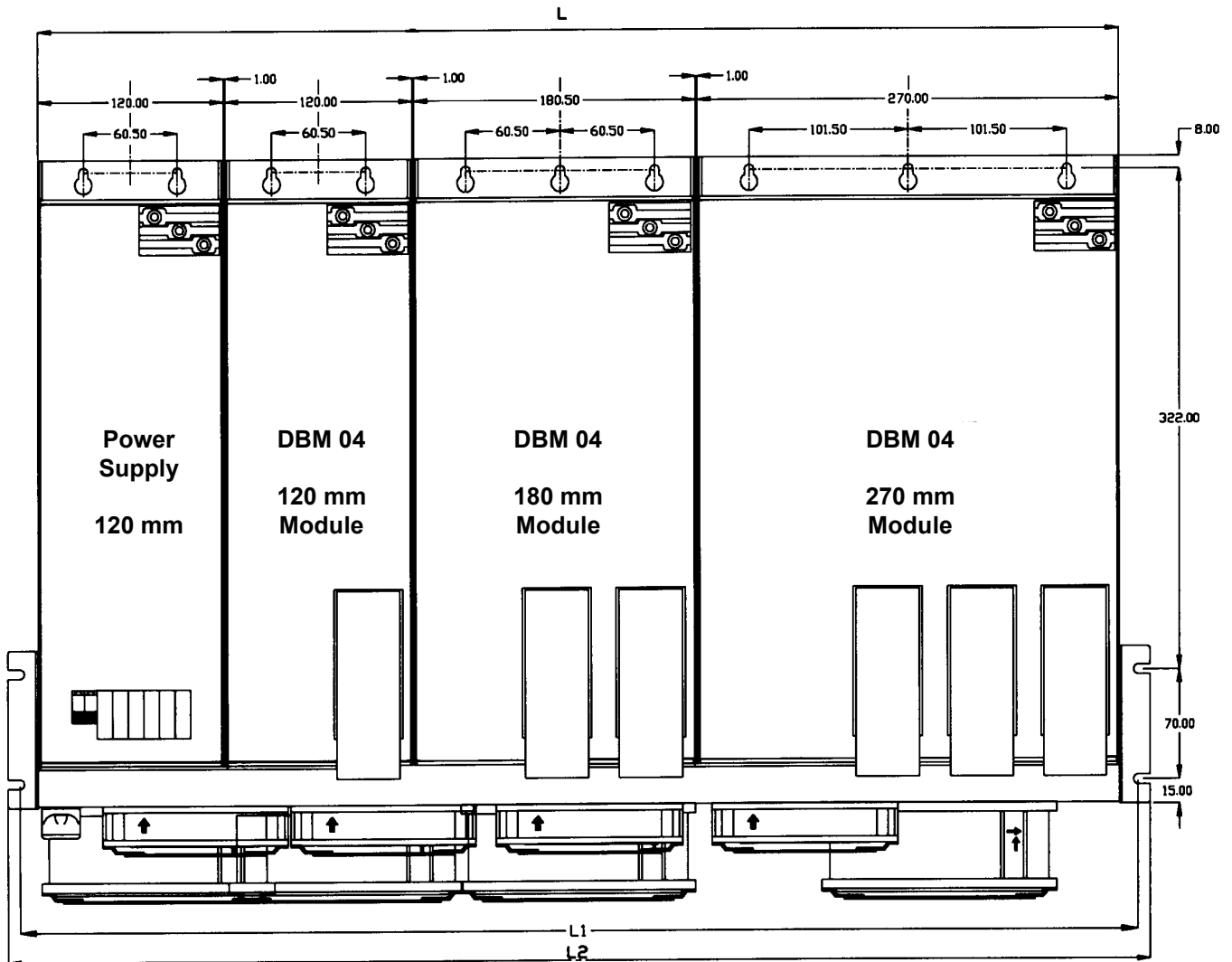

Configuration	L	L1	L2
1 DBM04 PS + 1 DBM04 120 mm	241	266	282
1 DBM04 PS + 1 DBM04 180 mm	301.5	326	342
1 DBM04 PS + 2 DBM04 120 mm	362	387	403
1 DBM04 PS + 1 DBM04 270 mm	391	416	432
1 DBM04 PS + 1 DBM04 120 mm + 1 DBM04 180 mm	422.5	447	463
1 DBM04 PS + 2 DBM04 180 mm	483	508	524
1 DBM04 PS + 3 DBM04 120 mm	483	508	524
1 DBM04 PS + 1 DBM04 120 mm + 1 DBM04 270 mm	512	537	553
1 DBM04 PS + 2 DBM04 120 mm + 1 DBM04 180 mm	543.5	568	584
1 DBM04 PS + 1 DBM04 180 mm + 1 DBM04 270 mm	572.5	597	613
1 DBM04 PS + 1 DBM04 120 mm + 2 DBM04 180 mm	604	629	645
1 DBM04 PS + 4 DBM04 120 mm	604	629	645

Note: the width of the Power Supply PS-120 is 180 mm. Contact our Sales Locations or Service Centers for the available configurations and dimensions with this Power Supply.

Fig. 1.2 Side View (Drill For M5 Screws)

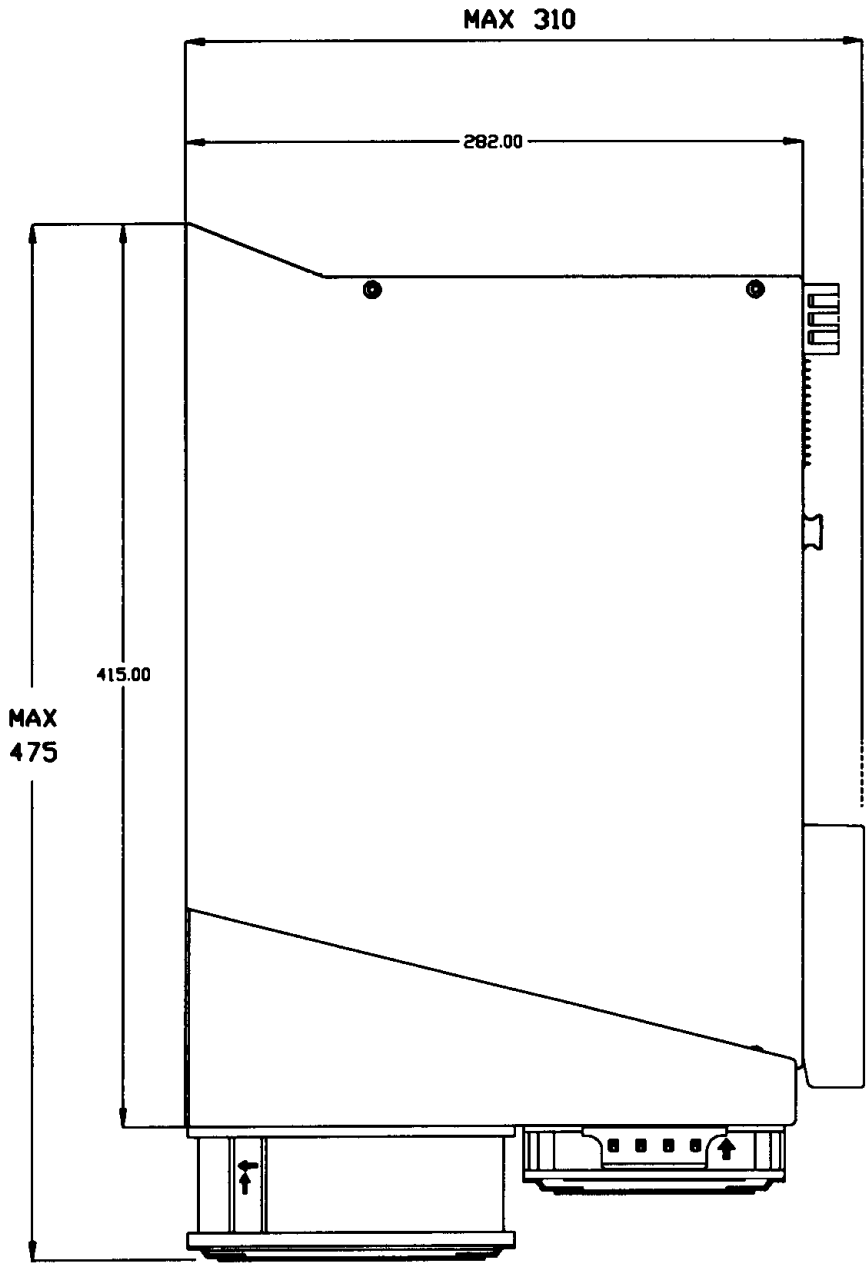

# 1.4 Component Identification

Fig. 1.3 Component Identification (DBM 04 15-8-8)

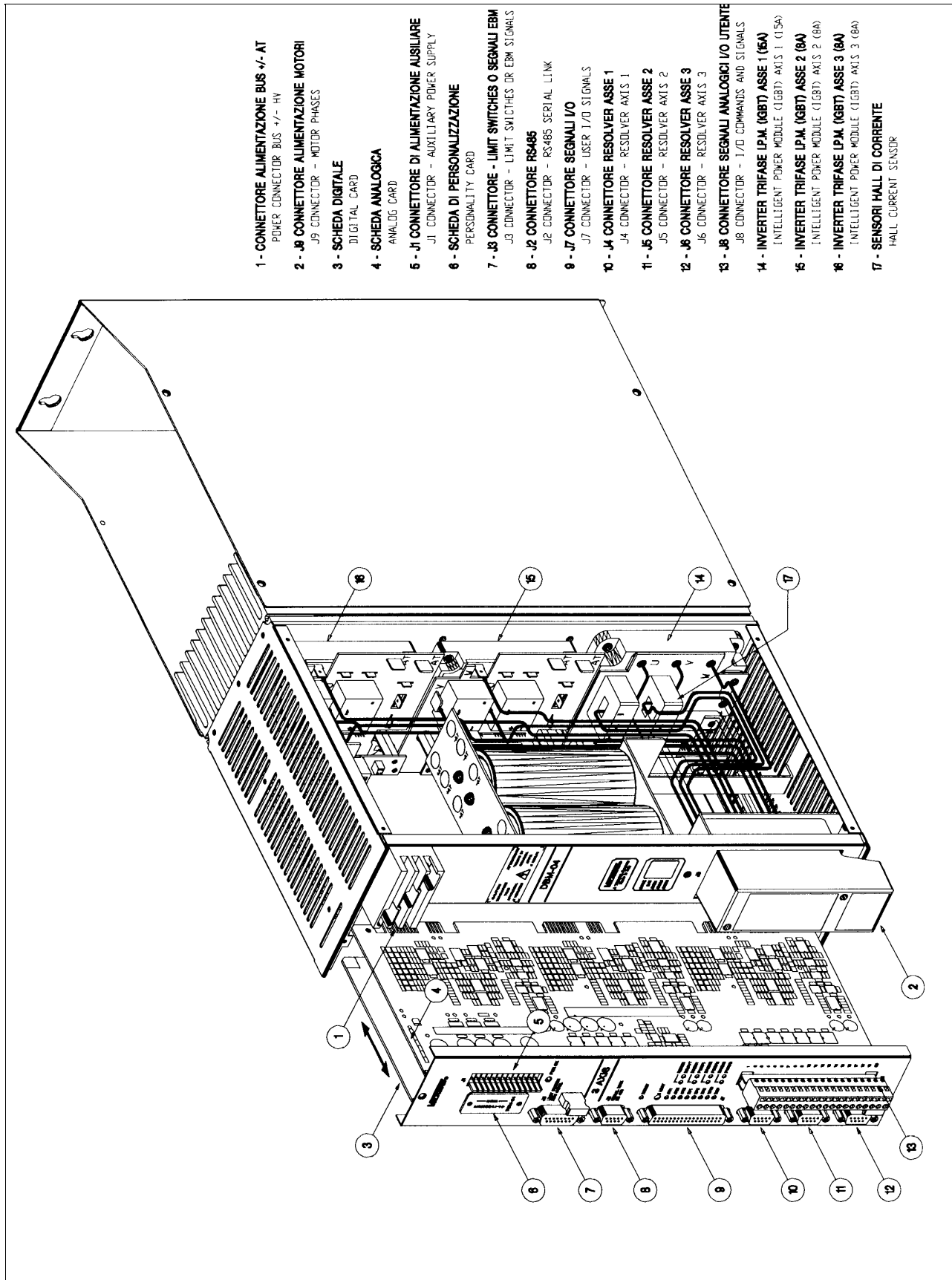



# 1.5 System Grounding

Fig. 1.4 EMC/Equipotential Bonding

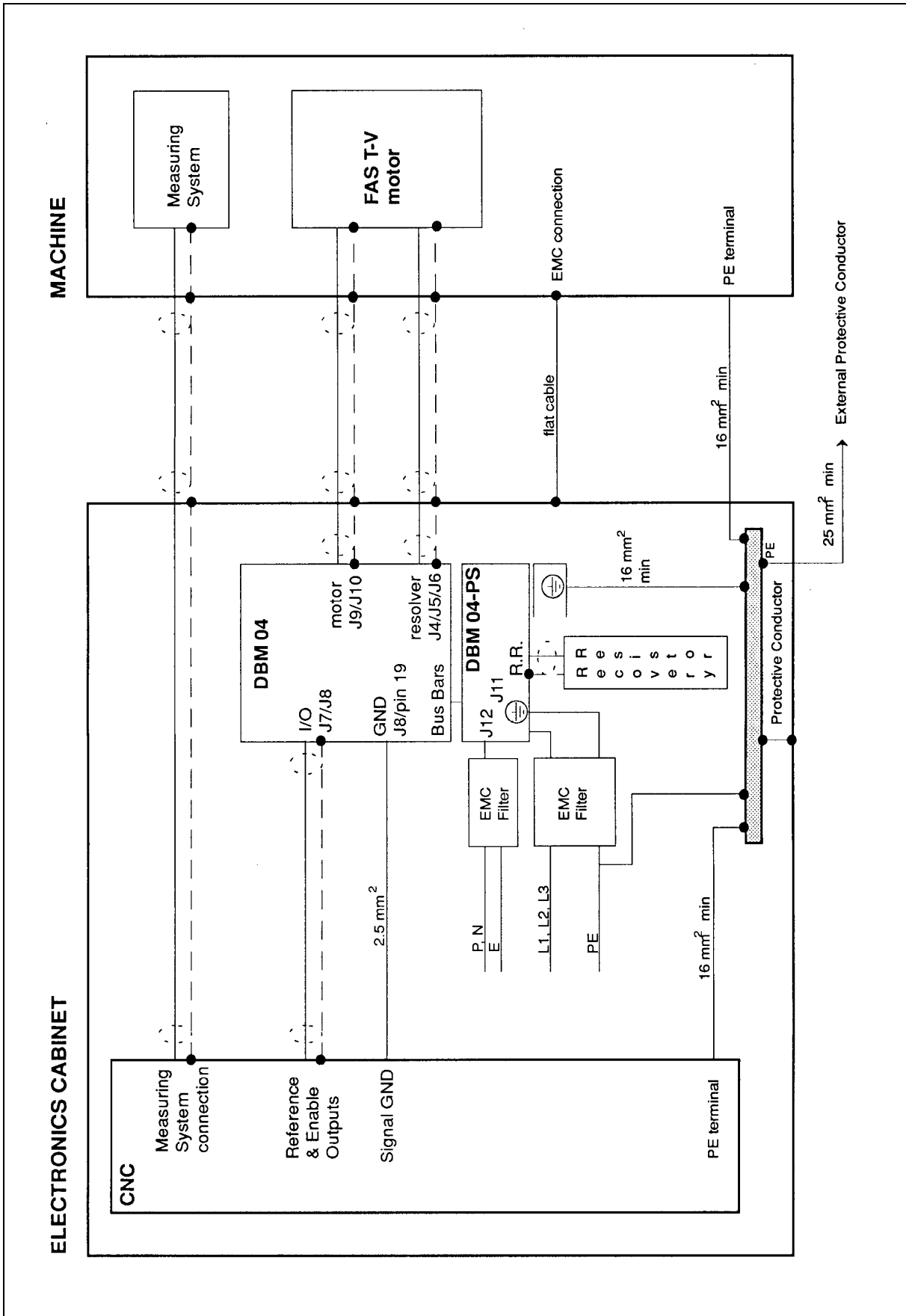

## 1.6 Options

- software programmable (from 128 to 16384 pulses per electrical revolution) simulated encoder with marker
- A/D 14 bit converter on the speed reference with the possibility of software choice between 12 bit standard conversion and 14 bit optional conversion
- R/D converter resolution: 8 arc/min 2-axis, 4 arc/min 2-axis, 2 arc/min 2-axis, 8 arc/min 3-axis, 4 arc/min 3-axis, 2 arc/min 3-axis
- installation and setup keypad
- PC communication package: see par. 2.11.2.1
- ADR function: external 24 Vdc UPS with added capacitance to recover braking energy (see Application Note GB-4528)
- frequency reference to use a velocity reference generated by Pulse Frequency Modulation (PFM) from 0 to 100 kHz instead of the standard analog signal (see Application Note I-4521)
- master-slave (electric shaft) special software for DBM 04 with expansion (see Application Note GB-4527)

## 1.7 Rating Plate

The following informations are supplied on the rating plate of DBM 04.

### 1.7.1 Power Supply

CODE:	CYZZZZ	where ZZZZ=model code
S/N:	AASS NNNNNN	where AA=year, SS=week, NNNNNN=serial number
Vin:	xxx V	nominal three phase input voltage
50/60 Hz	3-phase	
lin:	xxx A <sub>rms</sub>	nominal rms input current
lout nom:	xxx A <sub>rms</sub>	nominal rms output current
lout max:	xxx A	peak output current

### 1.7.2 Module

CODE: CY1ZZZ XX where 1ZZZ=model code; XX=option code  
 S/N: AASS NNNNNN where AA=year, SS=week, NNNNNN=serial number  
 3-phase  
 D.C.: XXX% module duty cycle, related to the max nominal current of the module (34A for 120mm, 53A for 180mm, 65A for 270mm)  
 Axis 1 C<sub>1</sub>C<sub>2</sub>C<sub>3</sub>-C<sub>4</sub> code for motor, resolver, simulated encoder (see below)  
 I<sub>out nom</sub> XX A<sub>rms</sub> nominal rms output current  
 I<sub>out max</sub> YYY A peak output current  
 Axis 2 C<sub>1</sub>C<sub>2</sub>C<sub>3</sub>-C<sub>4</sub> code for motor, resolver, simulated encoder (see below)  
 I<sub>out nom</sub> XX A<sub>rms</sub> nominal rms output current  
 I<sub>out max</sub> YYY A peak output current  
 Axis 3 C<sub>1</sub>C<sub>2</sub>C<sub>3</sub>-C<sub>4</sub> code for motor, resolver, simulated encoder (see below)  
 I<sub>out nom</sub> XX A<sub>rms</sub> nominal rms output current  
 I<sub>out max</sub> YYY A peak output current

C<sub>1</sub>C<sub>2</sub>C<sub>3</sub>-C<sub>4</sub> C<sub>1</sub>=pulses per electrical revolution (C=64, D=128, E=256, F=512, G=1024, H=2048, I=4096, L=8192, M=16384)  
 C<sub>2</sub>=motor poles (A=2, B=4, C=6, D=8, E=10, F=12)  
 C<sub>3</sub>=resolver poles (A=2, B=4, C=6, D=8, E=10, F=12)  
 C<sub>4</sub>=marker width (A=1, B=1/2, C=1/4, D=no marker)

### 1.7.3 UL Rating Plate

To comply with the UL requirements, the following data are shown on the rating plate of the Fan Assembly. These data are referred to the complete DBM 04 system, UL Recognized, that is Power Supply, one or more modules, fan assembly.

The Duty Cycle is related to the max nominal current of the Power Supply (65A for PS-Standard, PS-Standalone and PS-U).

The Flow Rate (F.R.) is the sum of the fan flow rates of the fan assembly.

Power Supplies and modules intended to be part of a complete DBM 04 system, UL Recognized, are marked "Part of a Recognized System".

Example:

CODE	CY2000 - CY2007 A0 - CY1200 A2 - CY1200 A9 - CY1200 A9 - CY4200						
V <sub>in</sub> 400 V <sub>ac</sub>	3-phase	50/60Hz	I <sub>in</sub> 27 A <sub>rms</sub>	- Duty Cycle			100 %
Auxiliary Input	V <sub>in</sub> 110/230 V <sub>ac</sub>	P <sub>in</sub> 240 W					
Fan Assembly	V <sub>in</sub> 115 V <sub>ac</sub>	P <sub>in</sub> 56 W	F.R. 560	m <sup>3</sup> /h			

**This page intentionally blank**

## SECTION 2 - INSTALLATION

**CAUTION:** make sure that the correct input voltage, 400V or 460V, has been set.

**Fig.2.1 PS-Standard and PS-6M - 400/460V Setting**

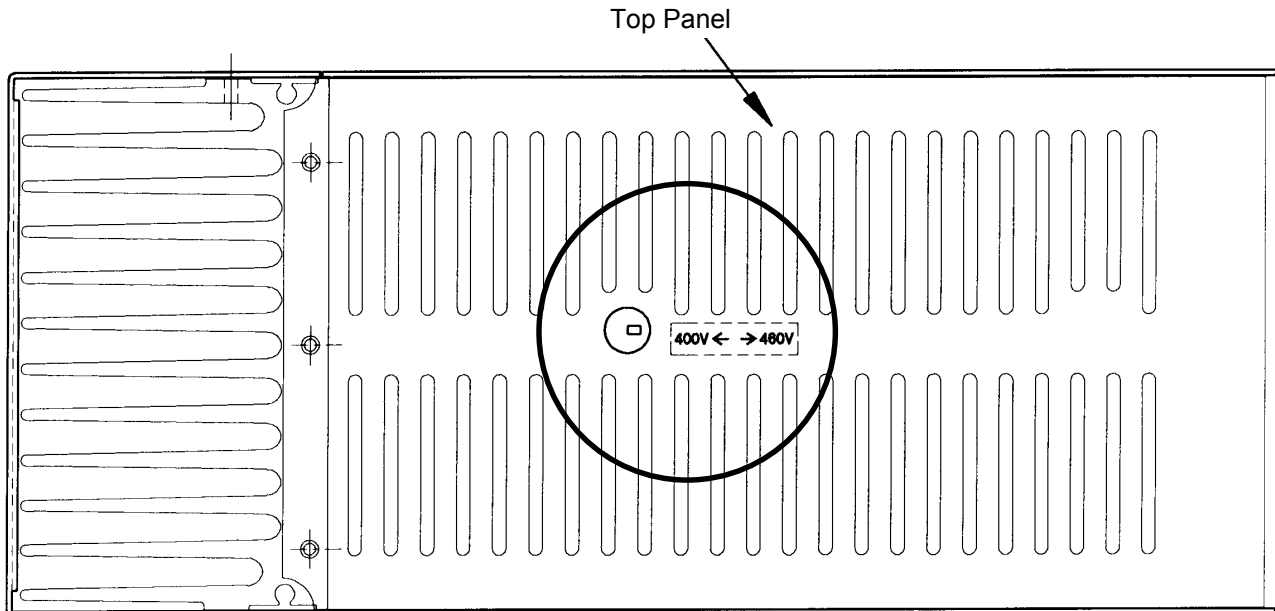

**CAUTION:** make sure that the correct wiring has been set for auxiliary input voltage on the PS-Standard and PS-6M front panel.

- connect the jumper on J12 connector to use 110 Vac

or

- disconnect the jumper on J12 connector to use 230 Vac

**Fig.2.2 PS-Standard and PS-6M - 110/230V Jumper**

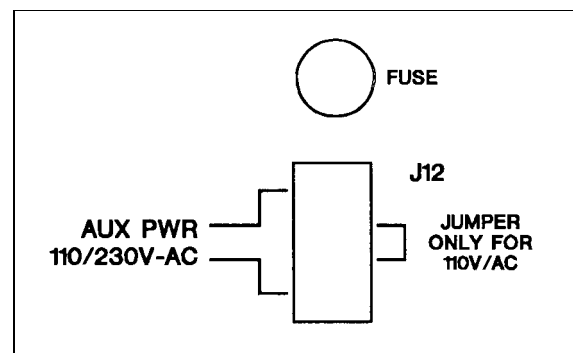

## **2.1 Fuses**

### **2.1.1 Internal Auxiliary Fuses**

#### **2.1.1.1 PS-Standard and PS-6M**

A delayed type fuse, rated 4A/250V, is provided on the front panel, to protect the auxiliary power circuit. The following types are approved:

- Mod.No.SPT 0001.2510 by Schurter AG
- Mod.No. ST520240 by Bussmann Div Cooper (UK) Ltd

#### **2.1.1.2 PS-Standalone and PS-120**

A delayed type fuse, rated 3.15A/250V, is provided on the internal base card, to protect the auxiliary power circuit. The following types are approved:

- Mod.No.SPT 0001.2509 by Schurter AG
- Mod.No. ST520231 by Bussmann Div Cooper (UK) Ltd

### **2.1.2 External Power Fuses (one in each phase of the power line)**

#### **2.1.2.1 PS Standard, PS-6M, PS-Standalone and PS-U**

**CAUTION:** *equipment suitable for use on a circuit capable of delivering not more than 5000 RMS symmetrical Amperes, 460V +10% maximum, when protected by semiconductor type fuses, mod.No.160-FEE, manufactured by Bussmann Div.Cooper (UK) Ltd*

#### **2.1.2.2 PS-120**

Semiconductor type fuses, mod.No.315-FM (315A/660Vac), manufactured by Bussmann Div.Cooper (UK) Ltd, are recommended.

## **2.2 Soft Start**

The soft start circuit (inrush current limiting) is built-in.

## 2.3 Transformers

### 2.3.1 Power Transformer

The system is designed to allow direct operation from a 400/460 Vac three phase power line, without isolation transformer. An isolation transformer may still be required to meet local safety regulations. It is the user responsibility to determine if an isolation transformer is required to meet these requirements.

To size the power transformer It is necessary to refer to the rated output power of the motors (the output power with 65K winding overtemperature is included in the Technical Data table of catalogs of servomotors), to sum the power of single axes, to multiply the sum by the contemporaneity factor (factors often utilized are  $K_c=0.63$  for 2 axes,  $K_c=0.5$  for 3 axes,  $K_c=0.38$  for 4 axes,  $K_c=0.33$  for 5 axes,  $K_c=0.28$  for 6 axes), and by a correction coefficient ( $=1.2$ ), accounting for the losses of the motor/drive system.

$$P = \sum P_{im} * K_c * 1.2 \quad [W]$$

### 2.3.2 Auxiliary Power Transformer - PS-Standard and PS-6M

A transformer for the auxiliary line is not necessary.

### 2.3.3 Auxiliary Power Transformer - PS-Standalone and PS-120

If data need to be saved in case of three phase power line failure, a 230 Vac monophas auxiliary line must be connected, via isolation transformer, to the PS-Standalone and PS-120 versions of Power Supply. This is not necessary for normal duty but only for data saving.

**CAUTION:** do not connect directly the auxiliary line but only through a dedicated, isolation transformer with 230Vac  $\pm 10\%$ , 50/60 Hz secondary voltage. Rated power must be 60VA for each module (e.g. 240VA for 4 modules)

## 2.4 Thermal sizing of cabinet

To calculate cabinet cooling requirements, table below provides estimated equipment power dissipation values. If the application employs continuous braking, it is necessary to include the recovery resistor power dissipation (use the nominal power of recovery resistor if actual application recovery dissipation is unknown).

Power Dissipation				
PS-Standard PS-6M PS-Standalone PS-U	PS-120	Module	IGBT's	Input Bridge
25 W	50 W	50 W	16 W/A	1 W/A

Example: with one PS-Standard, two modules, a total output current of 60 Arms and continuous unknown braking, the dissipated power is as follows.

$$P_d = 25 + (2 * 50) + (16 * 60[A]) + (1 * 60[A]) + 750 [\text{recovery resistor power}] = 1895 W$$

## 2.5 Recovery Circuit

The recovery circuit is formed by a switching regulator, a recovery transistor and a recovery resistance. While braking the motor returns energy which cannot be sent to the line since the rectifier circuit is not regenerative. Returned energy tends to increase the BUS BAR DC voltage. When HV reaches 680V (for 400Vac version) or 790V (for 460V version) the switching regulator brings the recovery transistor into conduction, thus connecting the recovery resistance in parallel with filter capacitors. The recovery resistance is formed by enameled wire fixed resistor(s).

If the recovery resistance works for intervals shorter than the time necessary to reach thermal equilibrium, the resistor can temporarily handle power levels up to 10 times the nominal power rating of the resistor (short time overload).

If not specifically requested, PS-Standard, PS-6M, PS-Standalone are provided with 8.2  $\Omega$ , 750W recovery resistor, while PS-U is provided with 12  $\Omega$ , 750W recovery resistor and PS-120 with 3.9  $\Omega$ , 1000W recovery resistor.

***WARNING:*** High Voltage. The recovery resistor is connected to the Bus Bar's and can have voltage  $\geq 810Vdc$

***WARNING:*** do not touch recovery resistor during operation to avoid scalds.

***CAUTION:*** an unusual application with motor driven by the load, a large portion of the time, could result in overheating of the recovery resistor.

*An unusual application with motor driven by high inertial load from high velocity in very short deceleration time could require a non standard recovery resistor.*

*It is suggested contacting our Service Centers.*

***CAUTION:*** shielding of the recovery resistor cable, provided in kit for test purposes, is recommended for ensuring compliance with the EMC standards.

***CAUTION:*** for UL approval in the end-use installation, the Dynamic Brake Unit Recovery Resistor shall have the connection wiring made with R/C (AVLV2) or insulated with R/C (YDPU2) or R/C (UZCW2)



## 2.6 Fan Assembly

The ventilation is provided by fans mounted under the modules. The size and the number of fans are according to the system configuration. Selection of the correct Fan Assembly is due by matching Fan Assembly width to the total of the DBM drives package (i.e. Fan = Power Supply and DBM module(s) and DBM expansion module(s)).

Fan input voltage is 230 Vac or 115 Vac or 24 Vdc.

**TAB. 2.1 - FAN ASSEMBLY**

Model Code	Fan Assembly Width mm	Input Voltage V	Input Power W	Total Flow Rate m3/h
CY4300, CY4318, CY4359, CY4360	240	24 Vdc	23	520
CY4301, CY4323, CY4337, CY4338	300	24 Vdc	46	1040
CY4302, CY4319, CY4339, CY4340	360	24 Vdc	46	1040
CY4303, CY4341, CY4342	390	24 Vdc	46	1040
CY4304, CY4320, CY4334, CY4343, CY4344	420	24 Vdc	57	1200
CY4305, CY4321, CY4331, CY4335, CY4345, CY4346	480	24 Vdc	69	1560
CY4306, CY4316, CY4347, CY4348	510	24 Vdc	69	1560
CY4307, CY4311, CY4349, CY4350	540	24 Vdc	69	1560
CY4308, CY4351, CY4352	570	24 Vdc	69	1560
CY4309, CY4312, CY4324, CY4336, CY4353, CY4354	600	24 Vdc	92	2080
CY4310, CY4355, CY4356	750	24 Vdc	92	2080
CY4315, CY4357, CY4358	660	24 Vdc	92	2080
CY4100, CY4118, CY4159, CY4160	240	230 Vac	64	485
CY4101, CY4123, CY4137, CY4138	300	230 Vac	128	970
CY4102, CY4119, CY4139, CY4140	360	230 Vac	128	970
CY4103, CY4141, CY4142	390	230 Vac	128	970
CY4104, CY4120, CY4134, CY4143, CY4144	420	230 Vac	147	1130
CY4105, CY4121, CY4131, CY4135, CY4145, CY4146	480	230 Vac	192	1455
CY4106, CY4116, CY4147, CY4148	510	230 Vac	192	1455
CY4107, CY4111, CY4149, CY4150	540	230 Vac	192	1455
CY4108, CY4151, CY4152	570	230 Vac	192	1455
CY4109, CY4112, CY4124, CY4136, CY4153, CY4154	600	230 Vac	256	1940
CY4110, CY4155, CY4156	750	230 Vac	256	1940
CY4115, CY4157, CY4158	660	230 Vac	256	1940
CY4200, CY4213, CY4214	240	115 Vac	56	560
CY4201, CY4215, CY4216	300	115 Vac	112	1120
CY4202, CY4217, CY4218	360	115 Vac	112	1120
CY4203, CY4219, CY4220	390	115 Vac	112	1120
CY4204, CY4221, CY4222	420	115 Vac	130	1300
CY4205, CY4211, CY4223, CY4224	480	115 Vac	168	1680
CY4206, CY4225, CY4226	510	115 Vac	168	1680
CY4207, CY4227, CY4228	540	115 Vac	168	1680
CY4208, CY4229, CY4230	570	115 Vac	168	1680
CY4209, CY4212, CY4231, CY4232	600	115 Vac	224	2240
CY4210, CY4233, CY4234	750	115 Vac	224	2240
CY4235, CY4236	660	115 Vac	224	2240

**CAUTION:** a free circulation must be guaranteed for the air flow.

## 2.7 Wire Type

### 2.7.1 Sizing of Wires

It is recommended to use Cu, stranded and/or solid wires, 60/75°C (140/167 °F), UL approved, per the following table.

Note that in the table the wires are sized according to the nominal current. The wires can be undersized if the actual rms current of the application is lower.

**Tab. 2.2 - Sizing of Wires**

	DBM 04 Model					Notes
	Power Supply		Axis			
	PS-Standard, PS-6M, PS-U, PS-Standalone	PS-120	3/9 to 15/42	25/70	35/90 to 60/180	-
Power Line and ground wiring (No.of wires x AWG)	4 x 6 AWG	4 x 2 AWG	-	-	-	-
Auxiliary Line wiring (No. of wires x AWG)	2 x 14 AWG	2 x 10 AWG	.	.	-	-
Motor Power wiring (No.of wires x AWG)	.	.	4 x 14 AWG	8 x 14 AWG	4 x 6 AWG	shielded
Recovery Resistor wiring (No.of wires x AWG)	2 x 10 AWG	2 x 6 AWG	.	.	.	shielded
Dc-Bus (+/-AT)	8 AWG (provided in kit)					-
Resolver wiring (No.of wires x AWG)	-		4 x 2 x 22/20 AWG			with 4 pair, each pair twisted and individually shielded with an independent overall shield

**Tab. 2.3 - AWG/mm<sup>2</sup> Conversion Table**

AWG	22	20	18	16	14	12	10	8	6	4	3	2	1	1/0
mm <sup>2</sup>	0.3	0.5	0.8	1.3	2.1	3.3	5.3	8.4	13	21	27	34	42	54

**Tab. 2.4 - Tightening torque of Power Connectors/Terminal Blocks**

Mfg	Moog	Phoenix Contact Gmbh			Harting Kga	
		DC-Bus	HDFK 4	HDFK 10	HDFK 25	Han16E
lb in	53	5-7	13.2-16	35	4.4	7
Nm	6	0.6-0.8	1.5-1.8	4	0.5	0.8

**Tab. 2.5 - Wire stripping length for Power Connectors/Terminal Blocks**

	Phoenix Contact Gmbh			Harting Kga		Wago Gmbh
	HDFK 4	HDFK 10	HDFK 25	Han16E	HanK 4/0	231-104
in	0.35	0.43	0.75	0.28	0.55	0.33
mm	9	11	19	7	14	8-9

Fig. 2.3A Power Supply - Front Panels

PS-Standalone

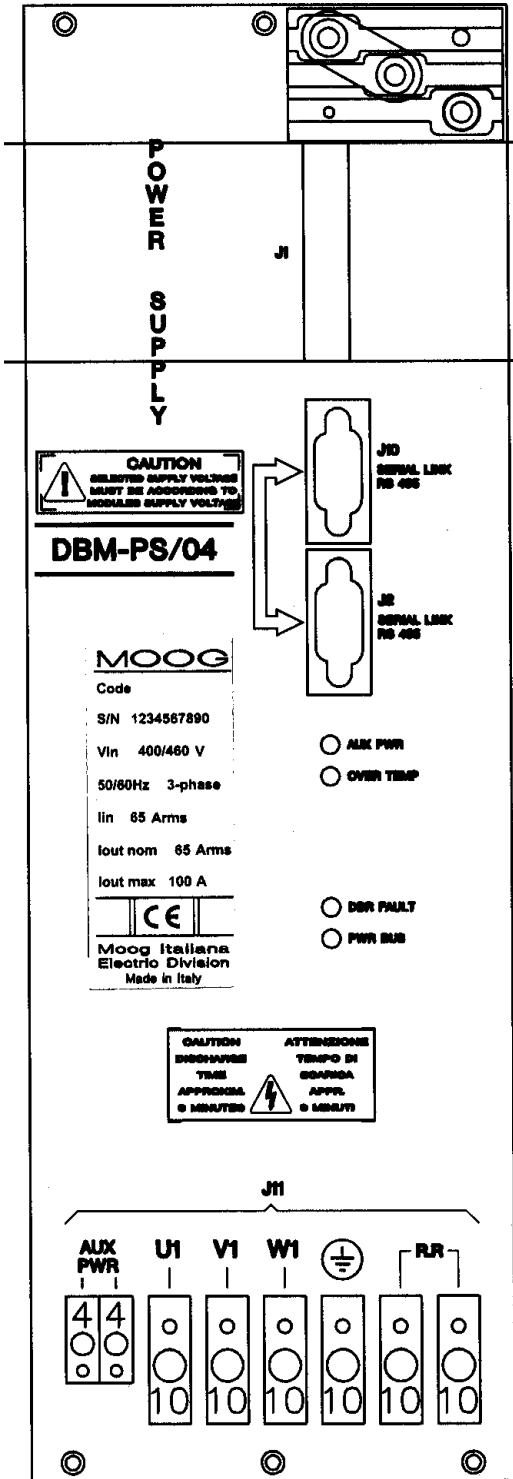

PS-Standard and PS-6M

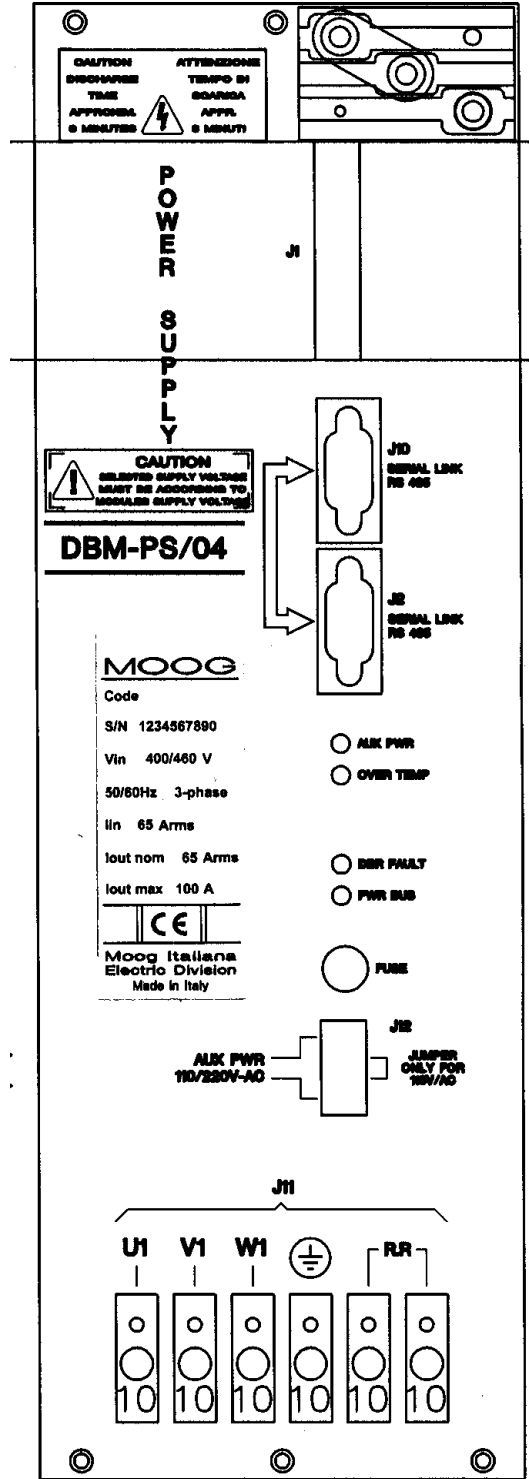

Fig. 2.3B Power Supply PS-120 - Front Panel

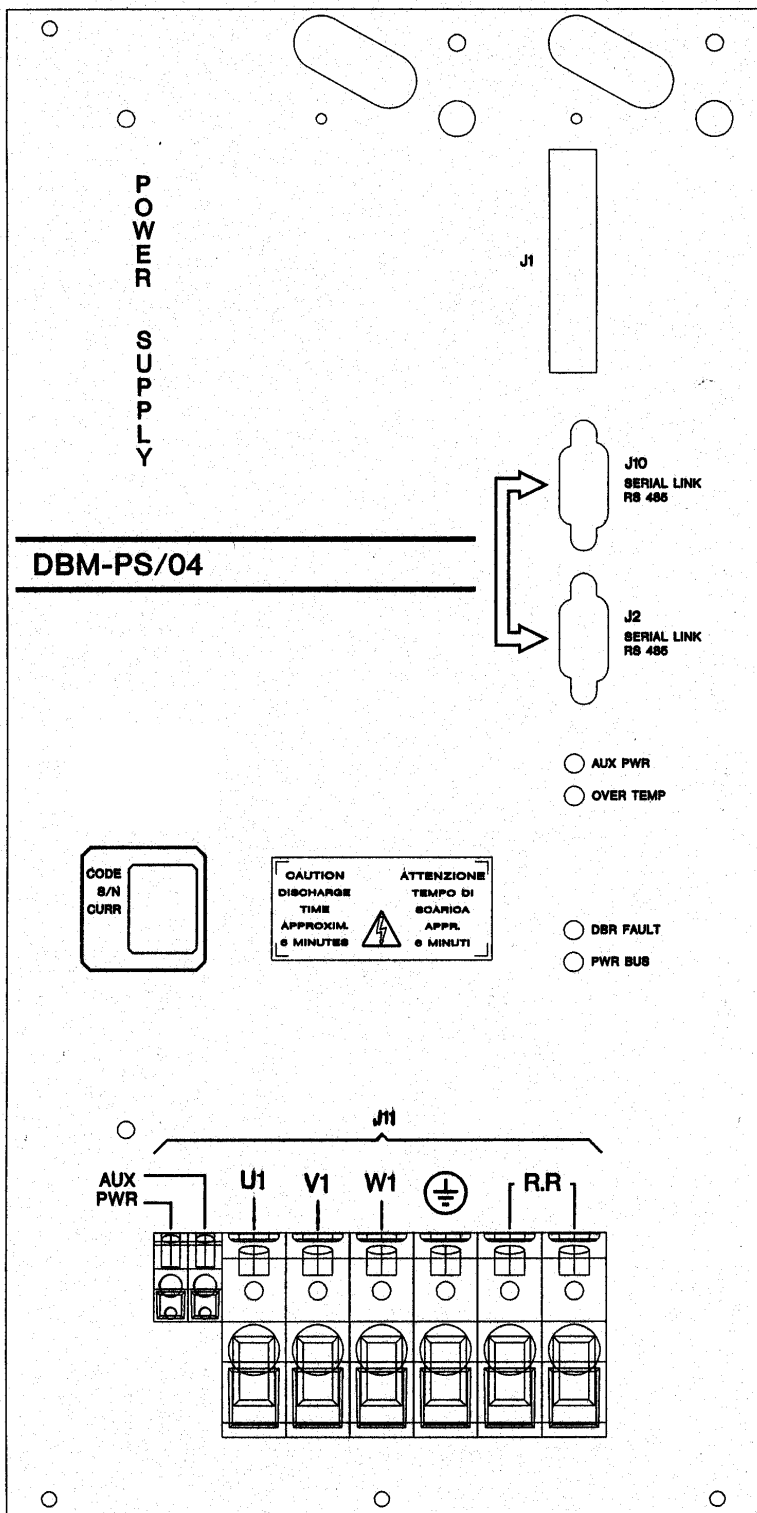
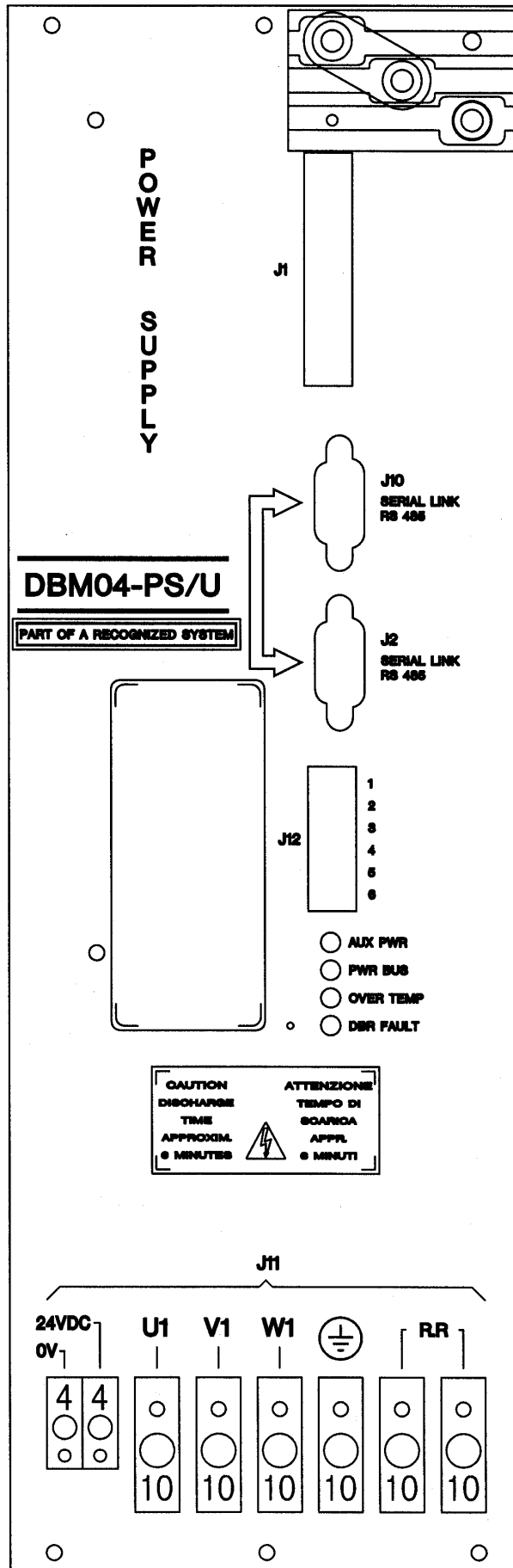

Fig. 2.3C Power Supply PS-U - Front Panel



## 2.8 Power Supply - Wiring

See Par.2.7 for sizing of power wires, tightening torque and wire stripping length. See Section 3 for shielding procedures according to EMC Directive.

### 2.8.1 Signal/ Auxiliary Wiring

#### Tab. 2.6 - Power Supply - J1 Conn. - Auxiliary Power Supply (to Modules)

Panel side: shrouded header with 13 male contacts

Wiring side: connector with 13 female contacts (provided in kit with cable)

Pos.	Function
1	Not connected (N.C.)
2	+18Vdc referred to -HV (540/620 Vdc)
3	-HV (540/620 Vdc)
4	158kHz square wave to high side drives
5	N.C.
6	N.C.
7	+18Vdc referred to logic 0V
8	- 18Vdc referred to logic 0V
9	+8Vdc referred to logic 0V
10	+8Vdc referred to logic 0V
11	Logic 0V
12	Resolver 0V
13	10 kHz sinusoidal wave for resolver and synchronism (carrier)

#### Tab. 2.7 - Power Supply - J2 Conn. - RS485 Port/Fault signals (to Modules)

Panel side: Sub-D with 9 male contacts

Wiring side: Sub-D with conductive shell, 9 female contacts (supplied with cable)

Pos.	Function
1	+ Rx (RS485 serial link)
2	N.C.
3	+ Tx (RS485 serial link)
4	Power supply binary coded faults (see Tab.2.8)
5	+ 5Vdc input referred to logic 0V
6	- Rx (RS485 serial link)
7	Logic 0V
8	- Tx (RS485 serial link)
9	Power supply binary coded faults (see Tab.2.8)

#### Tab. 2.8 - Power Supply binary coded faults

J2/pos. 4	J2/pos. 9	
0	0	OK
0	1	DBR FAULT. Recovery fault
1	0	OVER TEMP. Overtemperature
1	1	Not Used.

**Tab. 2.9 - Power Supply - J10 Connector - RS485 Port (to keypad or to converter)**

Panel side: Sub-D with 9 female contacts

Wiring side: Sub-D with 9 male contacts (supplied with the optional RS232/485 converter kit or with the optional keypad)

Pos.	Function
1	+Rx (RS485 serial link)
2	N.C.
3	+Tx (RS485 serial link)
4	N.C.
5	+5Vdc output referred to logic 0V for power supply
6	-Rx (RS485 serial link)
7	Logic 0V
8	-Tx (RS485 serial link)
9	N.C.

**2.8.2 Power Wiring****2.8.2.1 PS-Standard and PS-6M****Tab. 2.10 - J11 Connector - Power**

Power: Terminal Blocks Mod.No.HDFK 10 by Phoenix Contact GmbH

See Par.2.7 for sizing of power wires, tightening torque and wire stripping length

Name	Function
U1	"L1" phase, three-phase input voltage 400Vac (or 460Vac)
V1	"L2" phase, three-phase input voltage 400Vac (or 460Vac)
W1	"L3" phase, three-phase input voltage 400Vac (or 460Vac)
	Ground
R.R.	Recovery resistor
R.R.	Recovery resistor

**Tab. 2.11 - J12 Connector - Aux Power**

Panel side: shrouded open end header with 4 male contacts

Wiring side: connector Mod.No.231-104/026-000 by Wago GmbH (provided in kit)

See Par.2.7 for sizing of power wires, tightening torque and wire stripping length

Name	Function
AUX PWR	Auxiliary power supply 230Vac/110Vac
JUMPER	Jumper (see Fig.2.2)
JUMPER	Open=230Vac - Closed=110Vac
AUX PWR	Auxiliary power supply 230Vac/110Vac

### 2.8.2.2 PS-Standalone

#### Tab. 2.12 - J11 Connector - Power

Aux Power: Terminal Blocks Mod.No.HDFK 4 by Phoenix Contact Gmbh

Power: Terminal Blocks Mod.No.HDFK 10 by Phoenix Contact Gmbh

See Par.2.7 for sizing of power wires, tightening torque and wire stripping length

Name	Function
AUX PWR	Auxiliary power supply 230Vac
AUX PWR	Auxiliary power supply 230Vac
U1	"L1" phase, three-phase input voltage 400Vac (or 460Vac)
V1	"L2" phase, three-phase input voltage 400Vac (or 460Vac)
W1	"L3" phase, three-phase input voltage 400Vac (or 460Vac)
	Ground
R.R.	Recovery resistor
R.R.	Recovery resistor

### 2.8.2.3 PS-120

#### Tab. 2.13 - J11 Connector - Power

Aux Power: Terminal Blocks Mod.No.HDFK 4 by Phoenix Contact Gmbh

Power: Terminal Blocks Mod.No.HDFK 25 by Phoenix Contact Gmbh

See Par.2.7 for sizing of power wires, tightening torque and wire stripping length

Name	Function
AUX PWR	Auxiliary power supply 230Vac
AUX PWR	Auxiliary power supply 230Vac
U1	"L1" phase, three-phase input voltage 400Vac (or 460Vac)
V1	"L2" phase, three-phase input voltage 400Vac (or 460Vac)
W1	"L3" phase, three-phase input voltage 400Vac (or 460Vac)
	Ground
R.R.	Recovery resistor
R.R.	Recovery resistor



## 2.8.2.4 PS-U

**Tab. 2.14 - J11 Connector - Power**

Aux Power: Terminal Blocks Mod.No.HDFK 4 by Phoenix Contact Gmbh

Power: Terminal Blocks Mod.No.HDFK 10 by Phoenix Contact Gmbh

See Par.2.7 for sizing of power wires, tightening torque and wire stripping length

Name	Function
AUX PWR	Auxiliary power supply 24Vdc
AUX PWR	Auxiliary power supply 24Vdc
U1	"L1" phase, three-phase input voltage 400Vac (or 460Vac)
V1	"L2" phase, three-phase input voltage 400Vac (or 460Vac)
W1	"L3" phase, three-phase input voltage 400Vac (or 460Vac)
	Ground
R.R.	Recovery resistor
R.R.	Recovery resistor

**Tab. 2.15 - J12 Connector - Safety**

Panel side: shrouded open end header with 6 male contacts

Wiring side: connector Mod.No.231-106/026-000 by Wago Gmbh (provided in kit)

Pos.	Name	Function
1	OUTPUT	24Vdc (max 1A) output to feed an external relay during the anti-freewheeling. See Fig.2.4
2	SAFE 24V-1A	
3	SIGNAL	Output signal for safety. When the opto is OFF ( $\infty \Omega$ ) the DC-Bus is over 48V. When the opto is ON (2.7k $\Omega$ ) the DC-Bus is under 48V. See Fig.2.4
4	DC-BUS LOW	
5	AUX EXT	Input signal for safety. Normally connected to 24 Vdc. When not connected to 24 Vdc, the DC-Bus is discharged via the recovery resistor. See Fig.2.4
6	CONTACT	

**Fig. 2.4 - J12 Connector - Internal Circuitry**

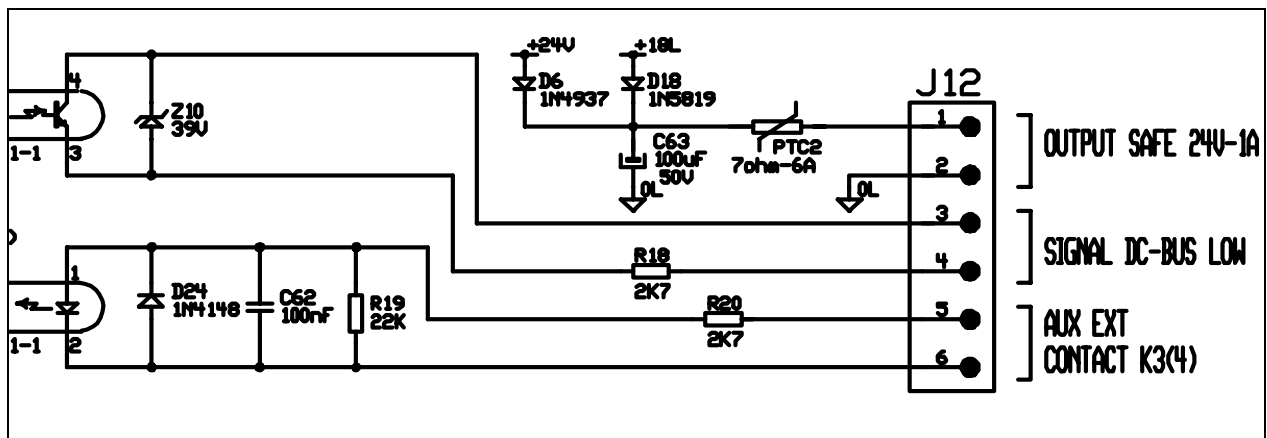

## 2.9 Power Supply - Led's

Tab. 2.16 - Power Supply - Led's

Name	Function
Yellow LED - PWR-BUS	BUS BAR voltage > 40Vdc <b>WARNING:</b> with PS-Standard and PS-6M, active only if the aux power supply is ON
Red LED - DBR FAULT	Recovery unit fault
Red LED - OVER TEMP	Module overtemperature via PTC (threshold 70 °C)
Green LED - AUX POWER	Auxiliary power supply OK

## 2.10 Power Supply - Internal Card Jumpers

**JP1 closed (default)** = connects a 120 Ω resistor between RX+ and RX- of serial link.

**JP2 closed (default)** = connects TX- of serial link to 0V via pull-down resistor

**JP3 closed (default)** = connects TX+ of serial link to +5V via pull-up resistor

Fig. 2.5 - Power Supply - Card Jumpers

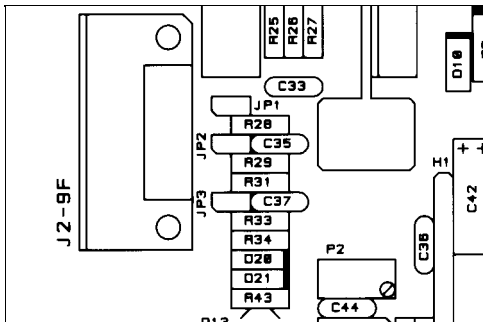

In case of multidrop, the following configuration must be used.

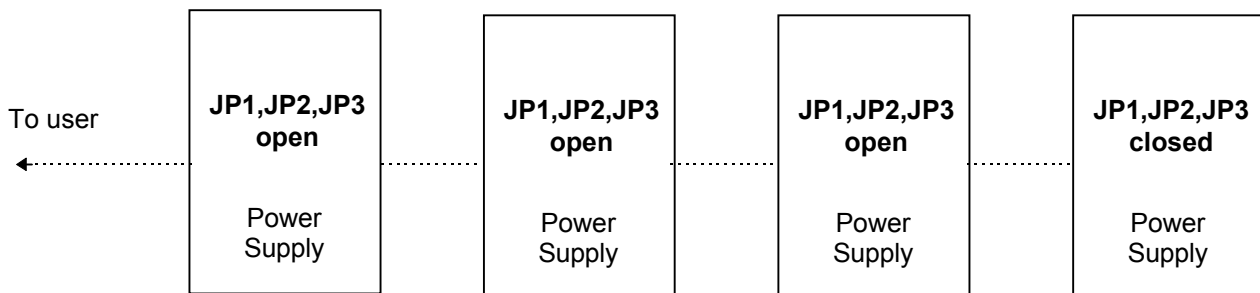

Fig. 2.6 Module - Removable Control Panels

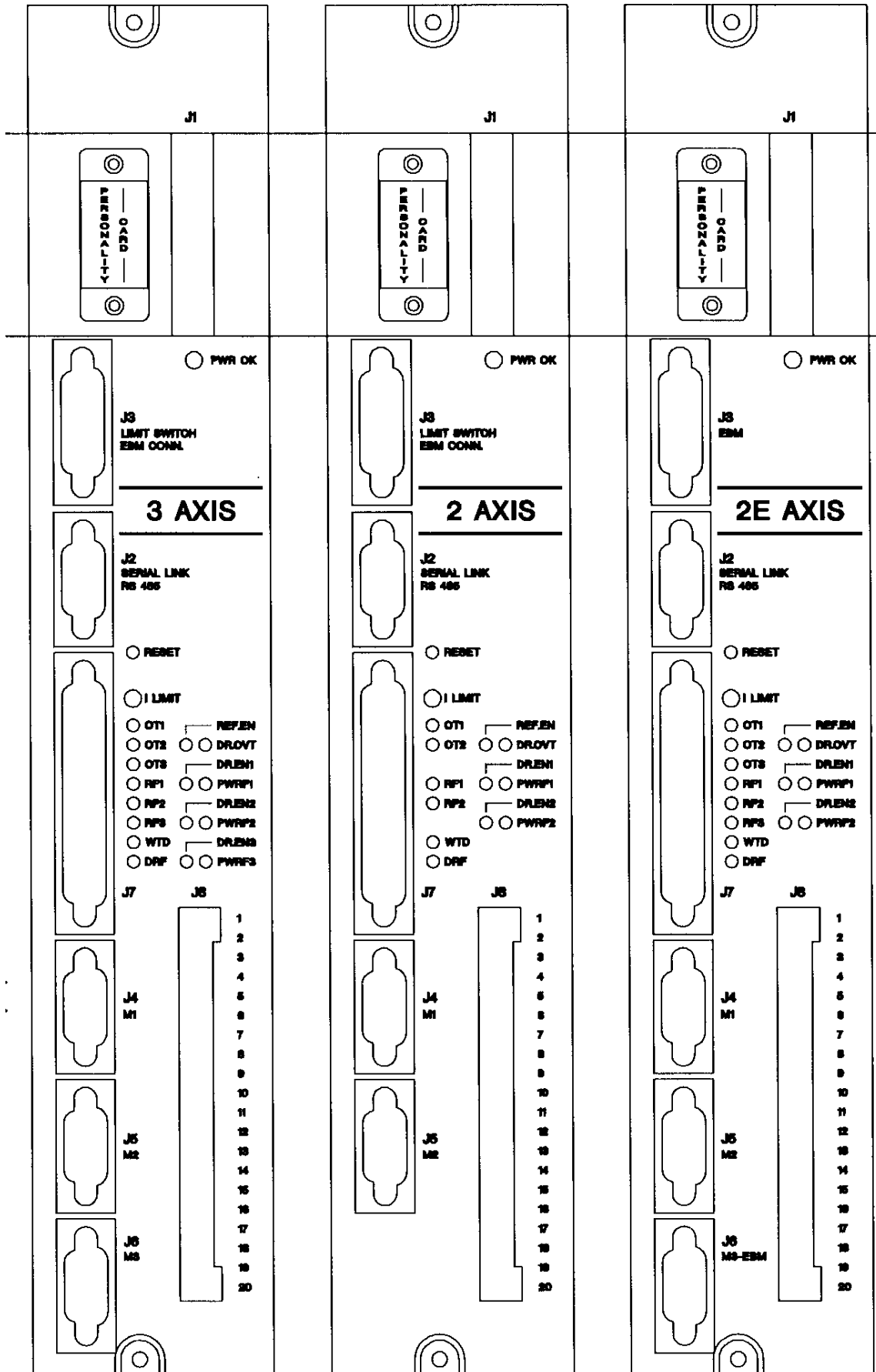

Fig. 2.7 Expansion-EBM - Removable Control Panel

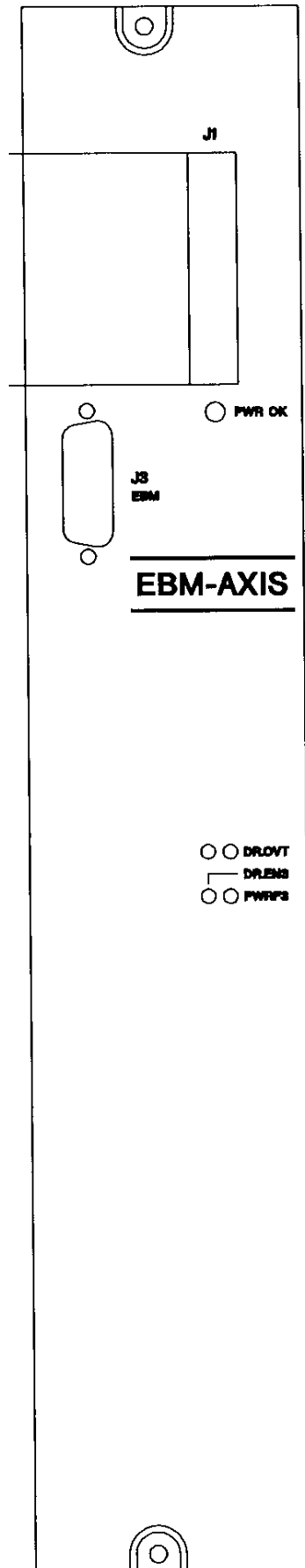

Fig. 2.8 Module (120 mm/180 mm) - Fixed Panels

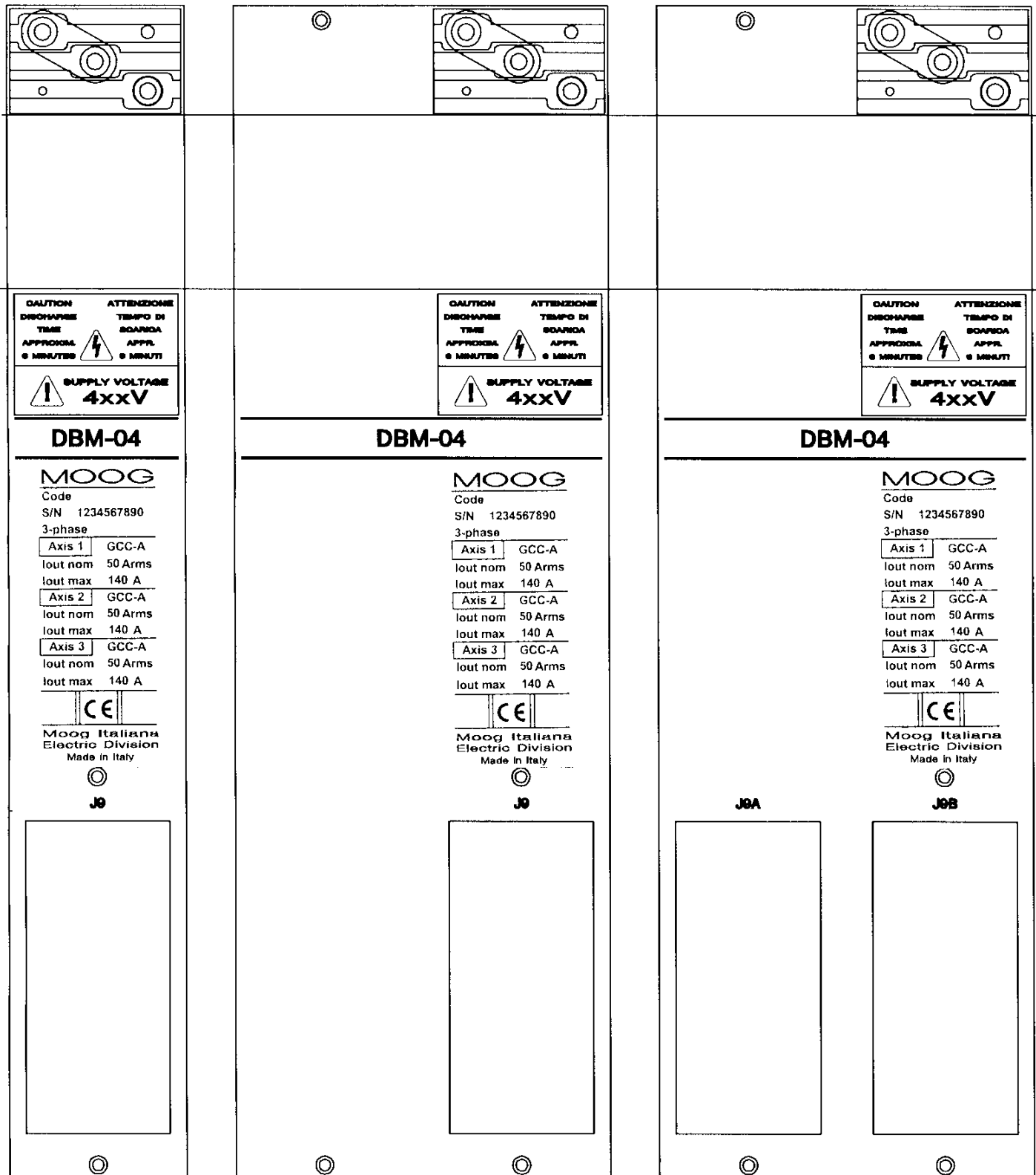
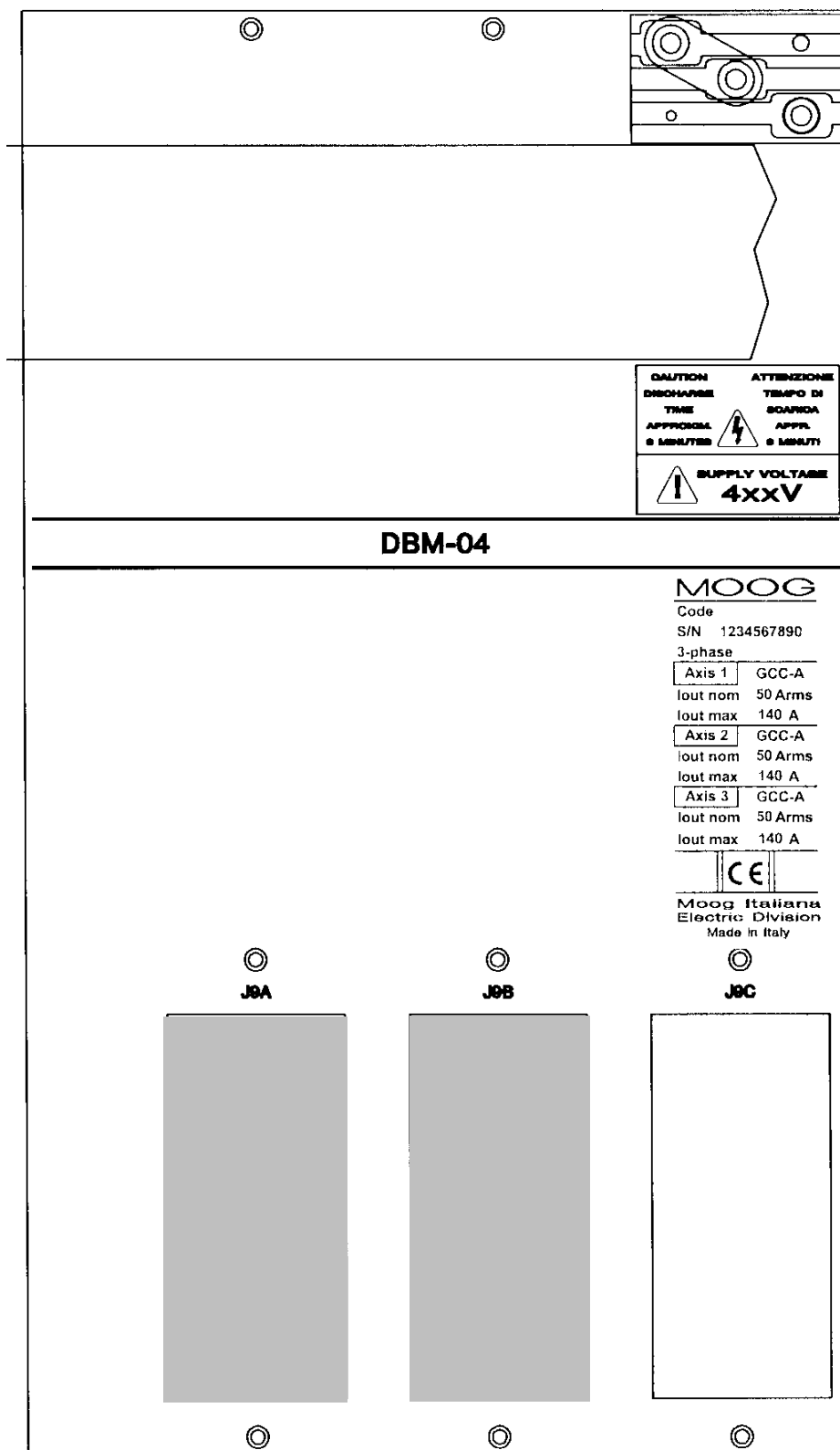

Fig. 2.9 Module/ Expansion (270 mm) - Fixed Panel



Note: the grey connectors are mounted only in some configurations (see tab.2.27 and 2.28)

## 2.11 Module Wiring

See Par.2.7 for sizing of power wires, tightening torque and wire stripping length. See Section 3 for shielding procedures according to EMC Directive.

### Tab. 2.17 - Module - J1 Connector - Auxiliary Power Supply (to PS/Modules)

Panel side: shrouded header with 13 male contacts

Wiring side: connector with 13 female contacts (supplied in kit with cable)

Pos.	Function
1	Not connected (N.C.)
2	+18Vdc referred to -HV (540/620 Vdc)
3	-HV (540/620 Vdc)
4	158kHz square wave to high side drives
5	N.C.
6	N.C.
7	+18Vdc referred to logic 0V
8	- 18Vdc referred to logic 0V
9	+8Vdc referred to logic 0V
10	+8Vdc referred to logic 0V
11	Logic 0V
12	Resolver 0V
13	10 kHz sinusoidal wave for resolver and synchronism (carrier)

### Tab. 2.18 - Module - J2 Connector - RS485 Port/Fault signals (to PS/Modules)

Panel side: Sub-D with 9 male contacts

Wiring side: Sub-D with conductive shell, 9 female contacts (supplied by with cable)

Pos.	
1	+Rx
2	N.C.
3	+Tx
4	Power supply binary coded faults (see Tab.2.19)
5	+5Vdc output referred to logic 0V
6	-Rx
7	logic 0V
8	-Tx
9	Power supply binary coded faults (see Tab.2.19)

### Tab. 2.19 - Module - Power supply binary coded faults

J2/pos. 4	J2/pos. 9	
0	0	OK
0	1	DBR FAULT. Recovery fault
1	0	OVER TEMP. Overtemperature
1	1	Not Used

## 2.11.1 Limit Switches/Expansion Wiring

The J3 connector allows, when the Expansion is not present, the availability of CW/CCW limit switches for each axis. With the input enabled (to 0V), the rotation is disabled in one direction and enabled in the other direction.

When the Expansion is present, the J3 connector is used for signal connection to the Expansion module.

**Fig. 2.10 - Limit Switches Wiring**

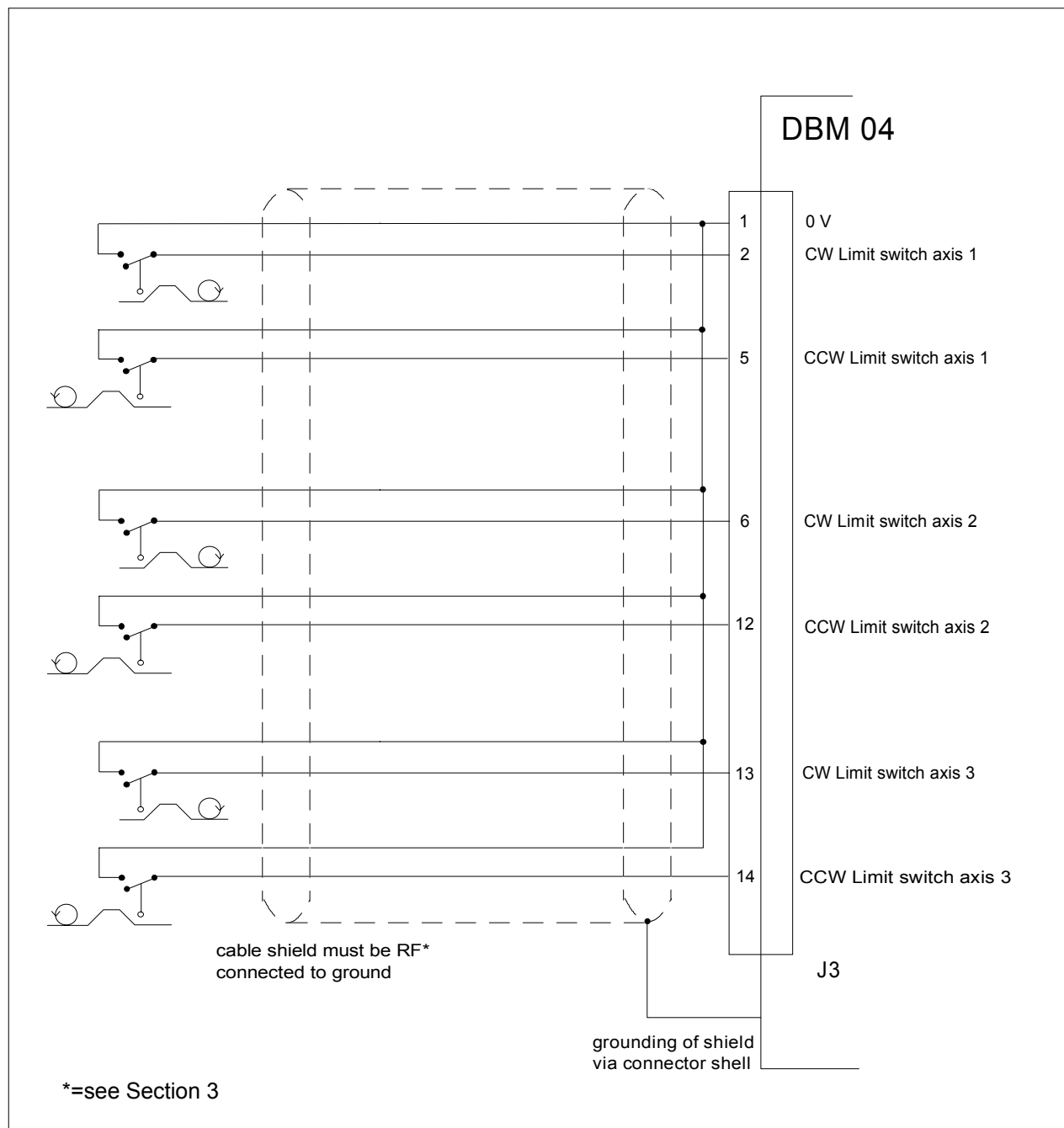



**Tab. 2.20 - Module - J3 Connector - Limit Switches (When EBM Expansion Is Not Present)**

Panel side: Sub-D with 15 female contacts

Present)

Wiring side: Sub-D with conductive shell, 15 male solder contacts

Pos.	
1	0V common
2	CW limit switch, axis 1
3	N.C.
4	N.C.
5	CCW limit switch, axis 1
6	CW limit switch, axis 2
7	N.C.
8	N.C.
9	N.C.
10	N.C.
11	N.C.
12	CCW limit switch, axis 2
13	CW limit switch, axis 3
14	CCW limit switch, axis 3
15	0V common

**Tab. 2.21 - Module/Expansion - J3 Connector - Expansion Connection**

Panel side: Sub-D with 15 female contacts

Wiring side: Sub-D with conductive shell, 15 male solder contacts

Pos.	
1	0V common
2	Auxiliary voltages referred to logic 0V not OK signal
3	Phase U reference current signal
4	Torque enabled signal
5	Short circuit signal
6	Overtemperature signal
7	Expansion present signal
8	Overtemperature signal
9	N.C.
10	Phase V reference current signal
11	Overtemperature signal
12	N.C.
13	BUS BAR fault signal
14	Auxiliary voltages referred to - HV (540/620 Vdc) not OK signal
15	N.C.

## 2.11.2 Resolver Wiring

Fig. 2.11 - Resolver Wiring

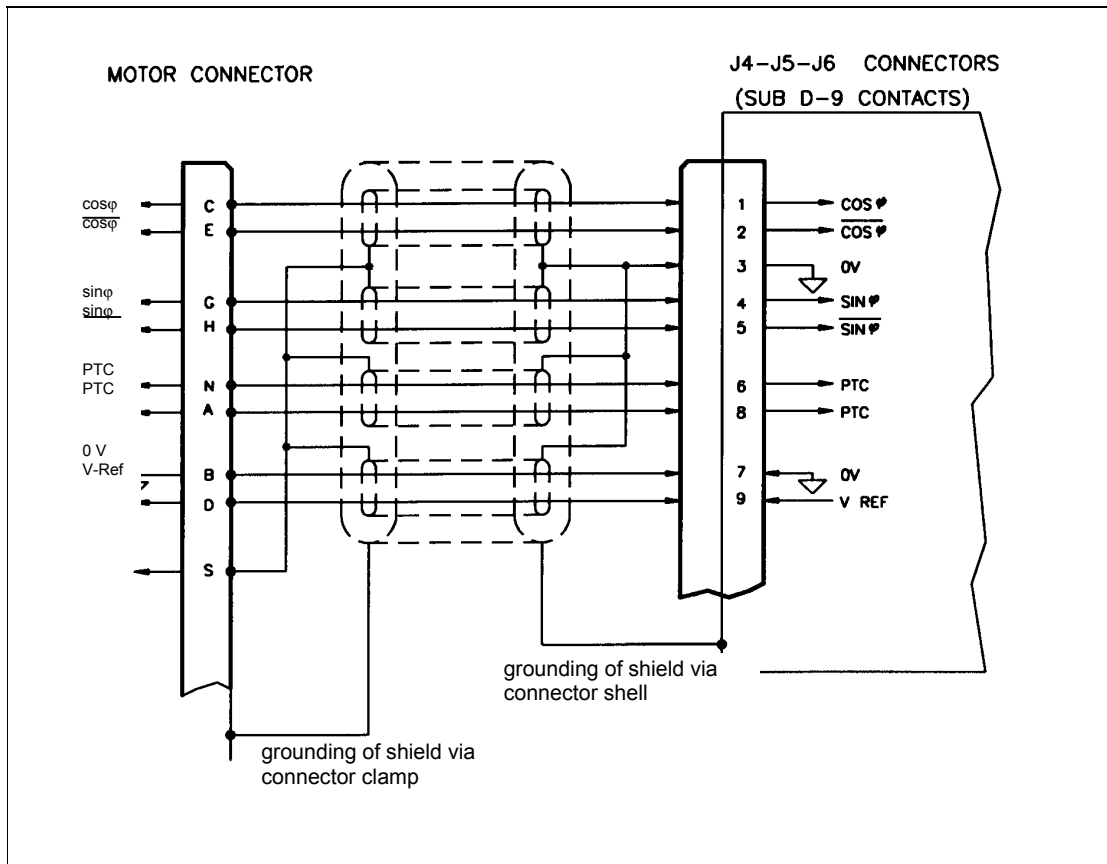

RESOLVER CONNECTOR, MOTOR SIDE		
Signal Type	FAS T/ FAS K	FAS N
	Pos.	Pos.
$\cos\phi$	C	1
$\overline{\cos\phi}$	E	2
V-Ref	D	10
0V	B	7
PTC	N	8
PTC	A	9
$\sin\phi$	G	11
$\overline{\sin\phi}$	H	12
shield	S	3

Each DBM module can be connected up to 3 resolvers. Axis 1 resolver must be connected to J4 M1 connector, axis 2 resolver to J5 M2 and axis 3 resolver to J6 M3.

Figure 2.11 shows the wiring lay-out of the resolver with differential output.

We recommend to use 4 pair cables, each pair twisted and individually shielded with an independent overall shield. 20 AWG (0.60 mm<sup>2</sup>) or 22 AWG (0.38 mm<sup>2</sup>) wire with low capacitance can be used. We suggest to use ground connections as shown in Fig. 2.11.

Cable length should not exceed 30 m (100 ft.). It is recommended that the signal cable and power cable be separated, if possible, through the use of independent duct (conduit) or by a distance of 12 inches (30 cm).

See Section 3 for shielding procedures according to EMC Directive.

**Tab. 2.22 J4-J5-J6 Connectors - Resolvers**

Panel side: Sub-D with 9 female contacts

Wiring side: Sub-D with conductive shell, 9 male solder contacts

Pos.	Name	
1	cos	Differential cos signal non-inverted input
2	$\overline{\text{cos}}$	Differential cos signal inverted input
3	Shield	Internally connected to 0V common
4	sin	Differential sin signal non-inverted input
5	$\overline{\text{sin}}$	Differential sin signal inverted input
6	PTC	Motor PTC input
7	0V	0V common. Special for 10kHz carrier
8	PTC	Motor PTC input
9	V ref	20 Vpp/ 10kHz sinusoidal output signal for supplying primary resolver winding (carrier)

### 2.11.3 I/O Wiring

All the signal cables must be separated from power cables by a distance  $\geq 30$  cm.  
See Section 3 for shielding procedures according to EMC Directive.

**REMARKS:**

- *DRIVE OK (J7 connector): it is suggested to connect the isolated output " DRIVE OK " to a remote control switch so that, if a fault occurs, the power supply is disconnected to avoid system damages.*
- *SIMULATED ENCODER SIGNALS (J7 connector):*
  - *in specially noisy environments it is suggested to connect a  $220 \div 680 \Omega$  resistor between  $A$  and  $\bar{A}$ ,  $B$  and  $\bar{B}$ ,  $C$  and  $\bar{C}$  at the receiver input.*
  - *for lengths in excess of 5 m (16 ft.) the cable must have 3 pairs, each pair twisted.*

**Fig. 2.12 - Speed Reference Wiring**

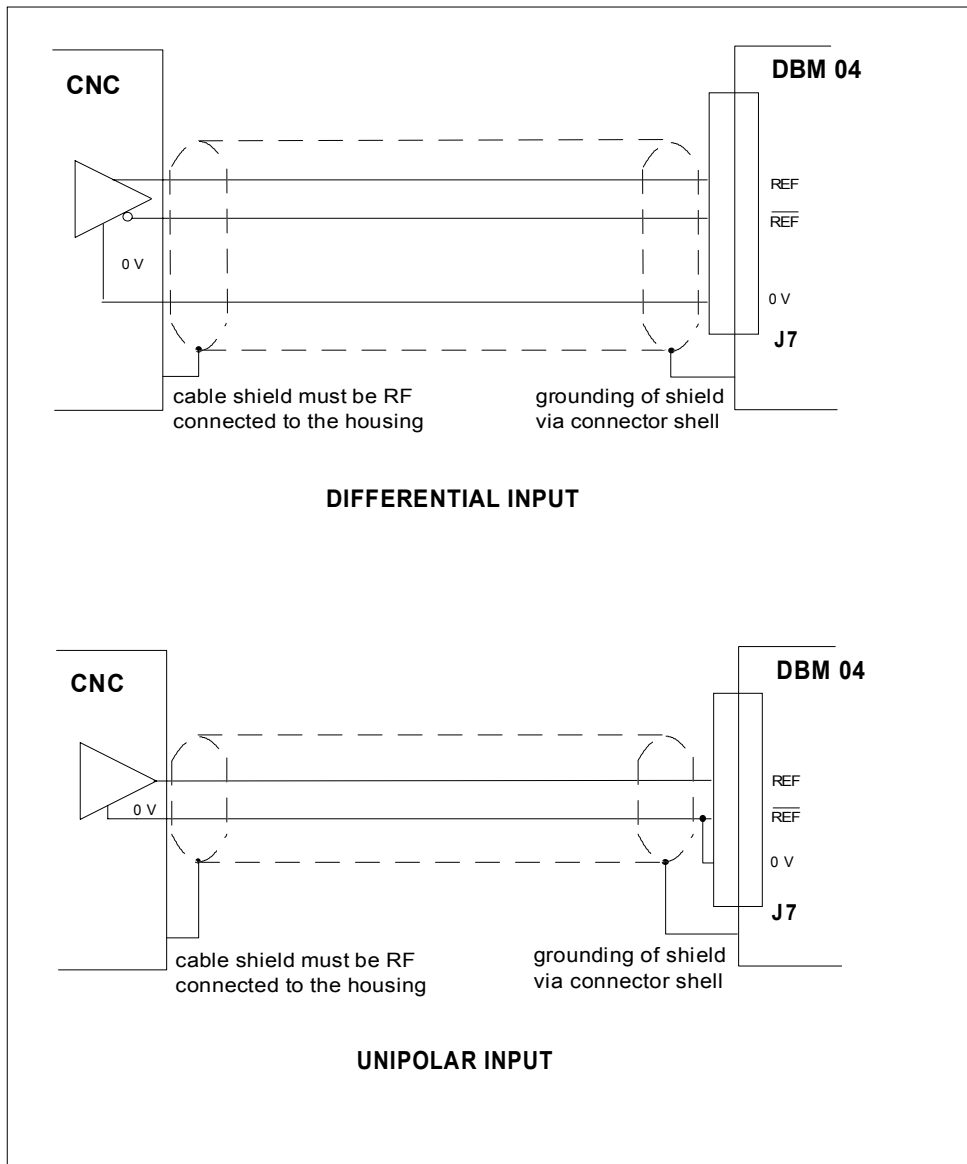

**Tab. 2.23 - J7 Connector - I/O Commands, Signals and Encoder Outputs**

Panel side: Sub-D with 37 female contacts

Wiring side: Sub-D with conductive shell, 37 male solder contacts

Pos.	Name	
1	0V	Logic 0V (it can be used as common for analog output supplies $\pm 15V$ )
2	A1	Encoder output: inverted phase A - motor 1
3	B1	Encoder output: inverted phase B - motor 1
4	C1	Encoder output: inverted phase C - motor 1
5	A2	Encoder output: inverted phase A - motor 2
6	B2	Encoder output: inverted phase B - motor 2
7	C2	Encoder output: inverted phase C - motor 2
8	A3	Encoder output: inverted phase A - motor 3
9	B3	Encoder output: inverted phase B - motor 3
10	C3	Encoder output: inverted phase C - motor 3
11	TP2	Testing point 2
12	ILIMIT3	Analog Current Limit input axis 3 0V = zero current +10V (or not connected) = max current
13	ILIMIT2	Analog Current Limit input axis 2 (0 to +10V )
14	ILIMIT1	Analog Current Limit input axis 1 (0 to +10V )
15		Shield. Internally connected to 0V
16	REF3	Differential inverting analog input for the speed reference signal (or torque ref. signal, see TC command) axis 3, max range $\pm 10V$ (see MR command). See Fig. 2.12
17	REF2	Differential inverting analog input for the speed reference signal (or torque ref. signal, see TC command) axis 2, max range $\pm 10V$ (see MR command). See Fig. 2.12
18	REF1	Differential inverting analog input for the speed reference signal (or torque ref. signal, see TC command) axis 1, max range $\pm 10V$ (see MR command). See Fig. 2.12
19	+15V	+15Vdc output (I max = 30mA)
20	A1	Encoder output: phase A - motor 1
21	B1	Encoder output: phase B - motor 1
22	C1	Encoder output: phase C - motor 1
23	A2	Encoder output: phase A - motor 2
24	B2	Encoder output: phase B - motor 2
25	C2	Encoder output: phase C - motor 2
26	A3	Encoder output: phase A - motor 3
27	B3	Encoder output: phase B - motor 3
28	C3	Encoder output: phase C - motor 3
29	TP1	Testing point 1

30		Shield. Internally connected to 0V
31	DRIVE OK 1 *	Drive OK output, axis 1. I <sub>max</sub> =5mA. 0V=not OK +5V=OK
32	DRIVE OK 2 *	Drive OK output, axis 2. I <sub>max</sub> =5mA. 0V=not OK +5V=OK
33	DRIVE OK 3 *	Drive OK output, axis 3. I <sub>max</sub> =5mA. 0V=not OK +5V=OK
34	REF3	Differential non-inverting analog input for the speed reference signal (or torque ref. signal, see TC command) axis 3, max range $\pm 10V$ (see MR command). See Fig. 2.12
35	REF2	Differential non-inverting analog input for the speed reference signal (or torque ref. signal, see TC command) axis 2, max range $\pm 10V$ (see MR command). See Fig. 2.12
36	REF1	Differential non-inverting analog input for the speed reference signal (or torque ref. signal, see TC command) axis 1, max range $\pm 10V$ (see MR command). See Fig. 2.12
37	-15V	- 15Vdc output (I max = 30mA)

\* Note:  $\overline{\text{LIMIT}}$  inputs available on request instead of DRIVE OK outputs

**Fig. 2.13 - Input/Output Wiring**

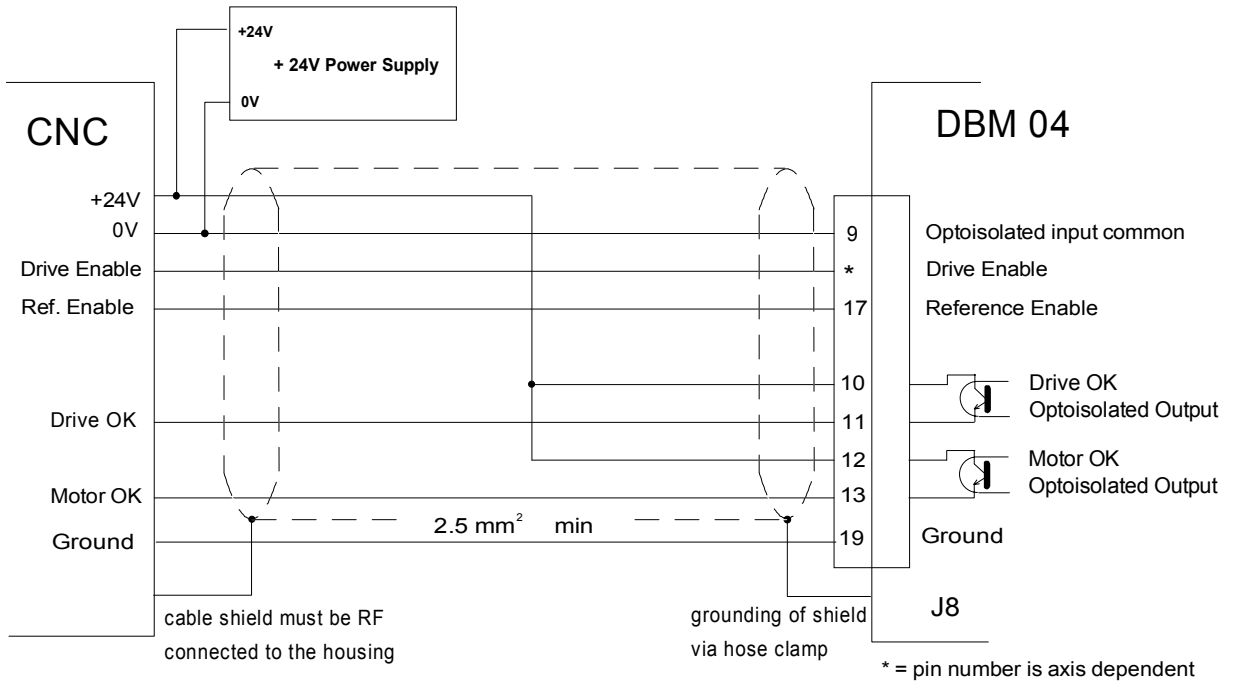

**+ 24V POWER SUPPLY**

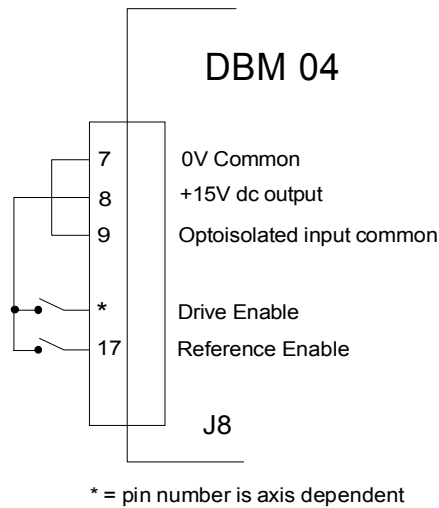

**+ 15V INTERNAL SUPPLY  
(for drive test)**

**Tab. 2.24 - J8 Connector - I/O Commands and Signals**

Panel side: shrouded open end header with 20 male contacts

Wiring side: connector with 20 female contacts, screw termination

Pos.	Name	
1	TACHO TEST 1	tachometer output, axis 1. Range: (ET*/10)V for max speed
2	TACHO TEST 2	tachometer output, axis 2. Range: (ET*/10)V for max speed
3	TACHO TEST 3	tachometer output, axis 3. Range: (ET*/10)V for max speed
4	ANALOG OUT 1	analog output 1. See Tab. 2.25/26 and ES, SO commands
5	ANALOG OUT 2	analog output 2. See Tab. 2.25/26 and ES, SO commands
6	ANALOG OUT 3	max current output, axis 3 (100% of max current = 10V)
7	0L	logic 0V
8	+15V	+15Vdc output (Imax = 30mA)
9	OPTO 0V	Optoisolated 0V
10	DRIVE OK	Collector of Drive OK optoisolator (see Fig.2.13)
11	DRIVE OK	Emitter of Drive OK optoisolator (see Fig.2.13)
12	MOTOR OK	Collector of Motor OK optoisolator (see Fig.2.13)
13	MOTOR OK	Emitter of Motor OK optoisolator (see Fig.2.13)
14	DRIVE EN1	Drive enable 1: optoisolated input for axis 1 torque enable. See Fig. 2.13
15	DRIVE EN2	Drive enable 2: optoisolated input for axis 2 torque enable. See Fig. 2.13
16	DRIVE EN3	Drive enable 3: optoisolated input for axis 3 torque enable. See Fig. 2.13
17	REF EN	Reference enable: optoisolated input for the confirmation of the common reference to the three axis (REF EN not active means no speed reference or zero torque)
18	REM RESET	Remote reset: optoisolated input for logic section reset, equivalent to push button on the front panel
19	GROUND	Ground. It must be connected to CNC ground with 2.5 mm <sup>2</sup> wire as short as possible
20	GROUND	Ground (connected to 19)

\* default ET=80

**Tab. 2.25 - ANALOG OUT - ADDRESS SETTING (SO COMMAND)**

SO	Address	SO	Address	SO	Address
1SO	Analog Out 1 first module	4SO	Analog Out 1 second module	7SO	Analog Out 1 third module
2SO	Analog Out 2 first module	5SO	Analog Out 2 second module	8SO	Analog Out 2 third module

**Tab. 2.26 - ANALOG OUT - OUTPUT SETTING (SO COMMAND)**

SO	Max Current	SO	Velocity Reference	SO	Velocity Error
SO1	axis 1	SO4	axis 1	SO7	axis 1
SO2	axis 2	SO5	axis 2	SO8	axis 2
SO3	axis 3	SO6	axis 3	SO9	axis 3



## 2.11.4 Motor Phases Wiring

Fig. 2.14 - Motor Phases Wiring (only one axis shown)

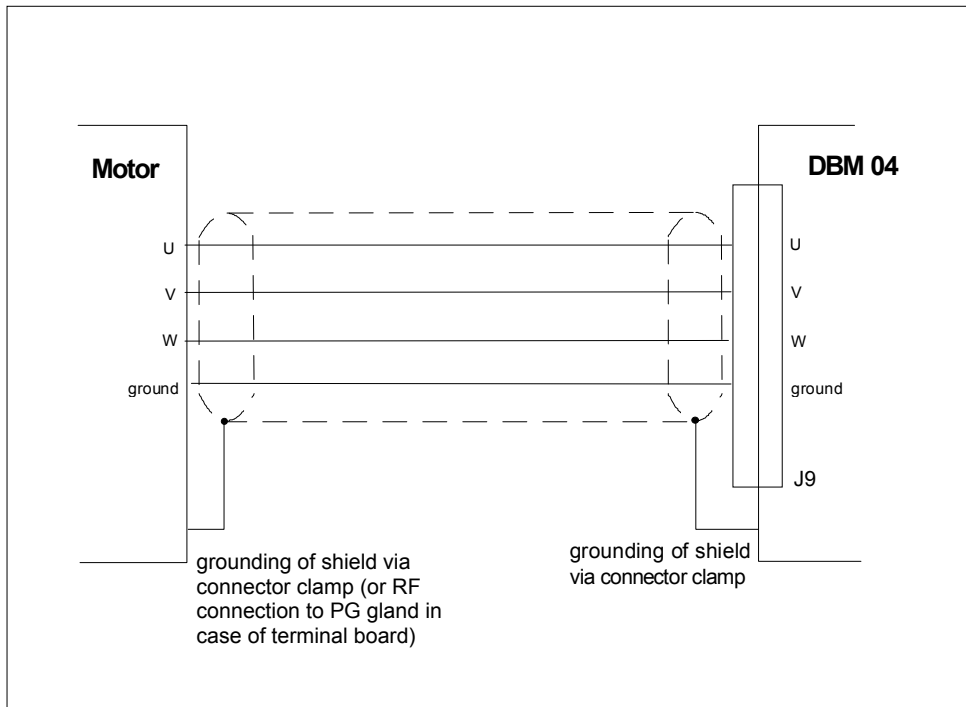

All the motor phases must be connected from J9 connector(s) to motor connector(s). Note that M1 always corresponds to the more powerful axis, while M3 must not be connected in 2 axis configuration.

There several motor power connections, depending on module configuration (see Tab.2.27 and Tab.2.28).

See Section 3 for shielding procedures according to EMC Directive.

**CAUTION:** the resolver wiring must match the motor wiring, i.e. the resolver cable running from M1 motor must be connected to J4 M1 connector, the resolver cable running from M2 motor must be connected to J5 M2 connector, the resolver cable running from M3 motor must be connected to J6 M3 connector.

**CAUTION:** the U-V-W motor phase sequence of the connector at the drive side must match the U-V-W motor phase sequence of the connector at the motor side.

**CAUTION:** do not parallel power connection cables to achieve requested section: this will increase the capacitance value at levels that may irreversibly damage the drive. If the value of capacitance of motor and cables, seen from drive output, exceeds 30 nF it is necessary to verify with Moog technicians the need of an adequate choke in series.

**Tab. 2.27 - J9 Connector(s) - Motor Phases (1/2)**

16 pins connector: Mod.No. Han16E by Harting Kga

4 pins connector: Mod.No.HanK 4/0 by Harting Kga

See Par.2.7 for sizing of power wires, tightening torque and wire stripping length

**Wiring side connector view and DBM04 Configurations**

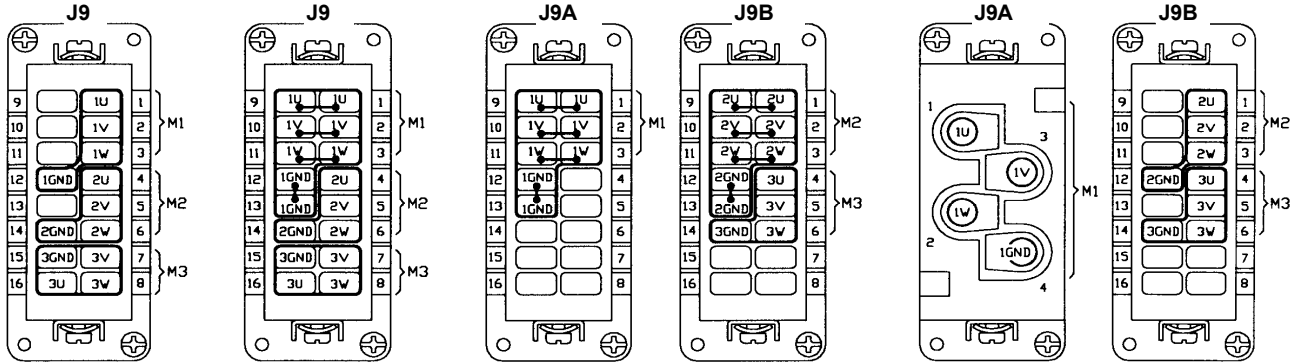

M1	M2	M3
3/9	3/9	3/9
6/15	3/9	3/9
8/22	3/9	3/9
15/42	3/9	3/9
6/15	6/15	3/9
8/22	6/15	3/9
15/42	6/15	3/9
8/22	8/22	3/9
15/42	8/22	3/9
15/42	15/42	3/9
6/15	6/15	6/15
8/22	6/15	6/15
15/42	6/15	6/15
8/22	8/22	6/15
15/42	8/22	6/15
8/22	8/22	8/22
15/42	8/22	8/22
15/42	15/42	6/15
15/42	15/42	8/22
3/9	3/9	
6/15	3/9	
8/22	3/9	
15/42	3/9	
6/15	6/15	
8/22	6/15	
15/42	6/15	
8/22	8/22	
15/42	8/22	
15/42	15/42	

M1	M2	M3
25/70	3/9	3/9
25/70	6/15	3/9
25/70	8/22	3/9
25/70	15/42	3/9
25/70	6/15	6/15
25/70	8/22	6/15
25/70	15/42	6/15
25/70	8/22	8/22
25/70	15/42	8/22
25/70	15/42	15/42
25/70	3/9	
25/70	6/15	
25/70	8/22	
25/70	15/42	

M1	M2	M3
25/70	25/70	3/9
25/70	25/70	6/15
25/70	25/70	8/22
25/70	25/70	15/42
25/70	25/70	

M1	M2	M3
35/90	3/9	3/9
35/90	6/15	3/9
35/90	8/22	3/9
35/90	15/42	3/9
35/90	6/15	6/15
35/90	8/22	6/15
35/90	8/22	8/22
35/90	15/42	6/15
35/90	15/42	8/22
35/90	15/42	15/42
35/90	3/9	
35/90	6/15	
35/90	8/22	
35/90	15/42	

**Tab.2.28 - J9 Connector(s) - Motor Phases (2/2)**

16 pins connector: Mod.No. Han16E by Harting Kga

4 pins connector: Mod.No.HanK 4/0 by Harting Kga

See Par.2.7 for sizing of power wires, tightening torque and wire stripping length

**Wiring side connector view and DBM04 Configurations**

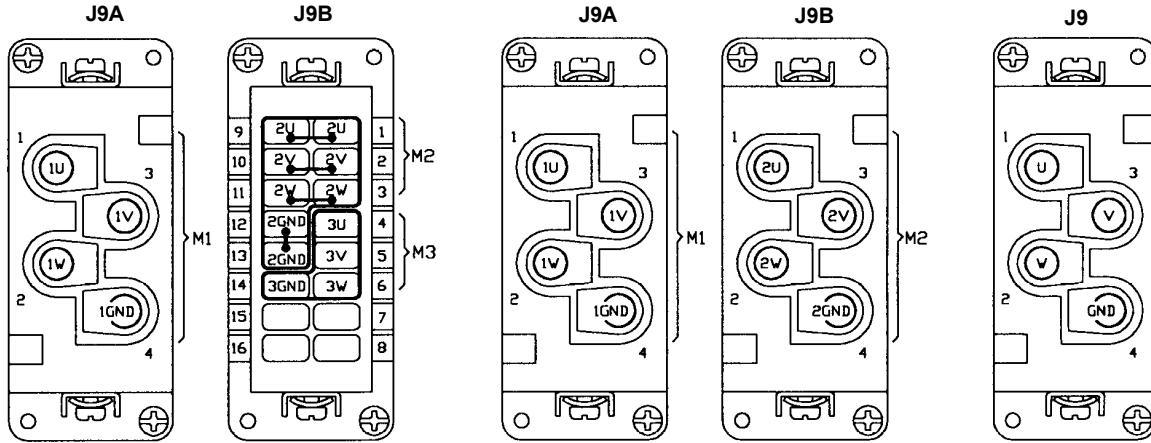

M1	M2	M3
35/90	25/70	3/9
35/90	25/70	6/15
35/90	25/70	8/22
35/90	25/70	

M1	M2
35/90	35/90

EBM
50/140
60/180

## 2.12 Module - Led's

Tab. 2.29 - Module - Led's

Name	Function
Red LED DRF	generic fault: the fault can correspond, according to the type, to a LED on the front end; if other red LED's are not on, out of the considered one, it is necessary to interrogate the drive via serial link to know the fault reason (see FA command)
Red LED WTD	Watch dog - signal; microprocessor circuit faults; this LED is on during reset
Red LED RF1	Resolver 1 fault - signal; resolver M1 fault, sin /cos signals interrupted, short circuit between signals or 10kHz carrier abnormal
Red LED RF2	Resolver 2 fault - signal; resolver M2 fault, sin /cos signals interrupted, short circuit between signals or 10kHz carrier abnormal
Red LED RF3	Resolver 3 fault - signal; resolver M3 fault, sin /cos signals interrupted, short circuit between signals or 10kHz carrier abnormal
Red LED OT1	Motor M1 overtemperature
Red LED OT2	Motor M2 overtemperature
Red LED OT3	Motor M3 overtemperature
Red LED DR.OVT	Module overtemperature
Red LED PWR1	Intelligent Power Module axis 1 fault
Red LED PWR2	Intelligent Power Module axis 2 fault
Red LED PWR3	Intelligent Power Module axis 3 fault
Green LED REF.EN	Reference enable
Green LED DR.EN 1	Axis 1 enable (see also ON command)
Green LED DR.EN 2	Axis 2 enable (see also ON command)
Green LED DR.EN 3	Axis 3 enable (see also ON command)
Green LED PWR OK	Auxiliary power OK

## 2.13 Personality Card Jumpers

**WP (default: open)**: if closed, the EEPROM is write protected and the Save (SV) command is disabled

**G1 (default: open)** : if closed, connects TX- of serial link to 0V via pull-down resistor

**G2** : if closed, gives priority to "opto" , if open gives priority to "keypad"

**G3 (default: open)** : if closed, set 9600 Baud rate and basic address 1

**G4 (default: open)** : if closed, connects TX+ of serial link to 5V via pull-up resistor

**G5 (default: open)** : if closed, connects a 120  $\Omega$  resistor between RX+ and RX- of serial link

**CAUTION:** *it is recommended to close the WP jumper at the end of installation and setup.*

Fig. 2.15 - Personality Card

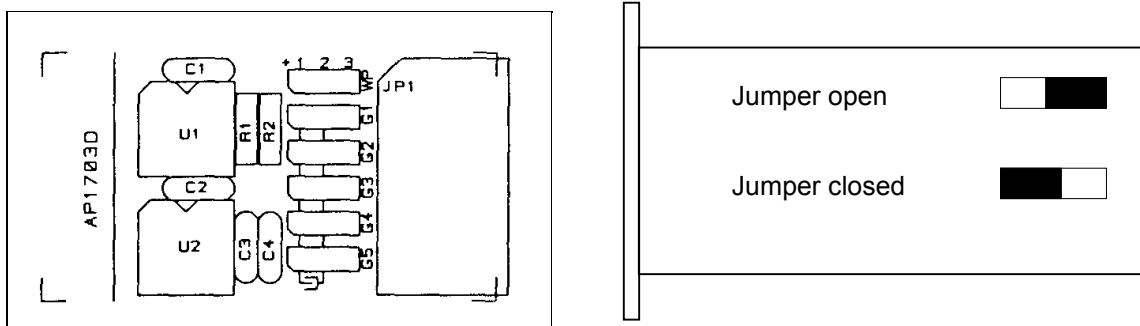

### 2.13.1 G2 Jumper: "Keypad" or "Opto" Priority

The jumper G2 on the personality card gives priority to keypad or to opto to execute "Drive Enable" command. " Drive Enable" opto isolated signals are connected to J8/ pos.13, 14, 15.

**G2 open** = keypad priority = the keypad (or the device connected to the serial link) is the master, i.e. it allows to enable or disable motor current, whereas the optocouplers can only disable (protection); they can enable after resetting only.

The "Drive Enable" and "Reference Enable" opto-isolated signals must be driven at +15V.

Such a procedure should be followed during installation and drive test.

**G2 closed** = opto priority = the optocouplers are the master and the keypad can only be used for parameters setup.

Note:

1. See par.2.16.1 if the keypad does not communicate with the drive
2. "Drive Enable" priority is different from the use of the analog or digital reference. You can choose an analog or digital reference by "AR" (Analog) or "DR" (Digital) commands, and save. The drives are supplied set to digital reference "DR".

### 2.13.2 G1-G4-G5 Jumpers: Link Termination's

By default G1, G4 and G5 jumpers on the personality card are open (no link termination's on modules). In fact, usually, it is not necessary to close G1, G4 and G5 jumpers because the link termination's are already closed on the power supply; anyway, in specially noisy environments, could be necessary to close them also, as follows.

- **Environment without noise**

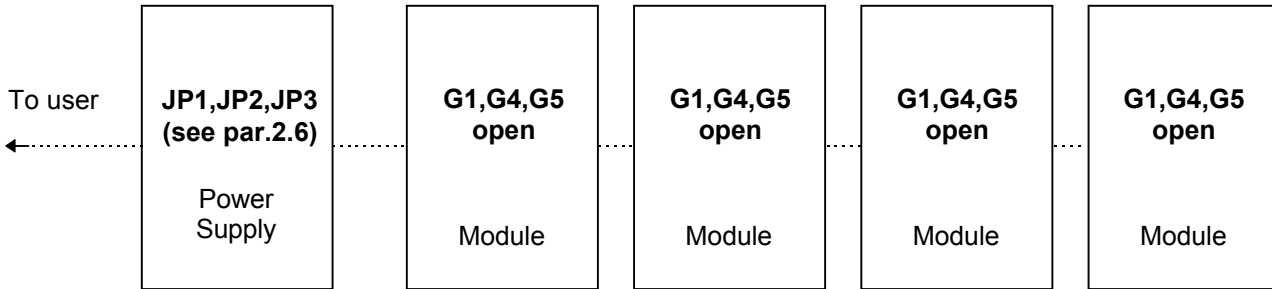

- **Specially noisy environment**

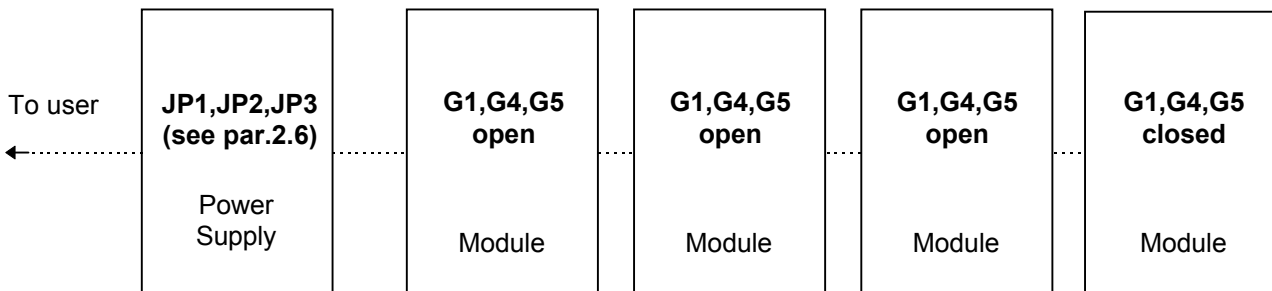

### 2.13.3 G3 Jumper: Basic Configuration

The jumper G3 on the personality card allows, if closed, to set 9600 Baud rate and basic address 1. This configuration can be used to restore the communication in case of fault of the serial link. When the communication has been restored, the G3 jumper must be open.

### 2.13.4 WP Jumper: Write Protection

The jumper WP on the personality card allows, if closed, to write protect the EEPROM. If closed, the Save (SV) command is disabled.

**CAUTION:** *it is recommended to close the WP jumper at the end of installation and setup.*

## 2.14 Potentiometer/Button

Tab. 2.30 - Potentiometer/Button

I LIMIT POTENTIOMETER	Peak current control. A full CCW rotation will set the current to zero. A full CW rotation will set the current to 100%.
RESET BUTTON	Digital control card reinitialization and reset of protections.

## 2.15 Input/Output Characteristics

Tab. 2.31 - Input/Output Characteristics

OPTOISOLATED INPUTS Drive enable 1,2,3 Reference enable Remote reset	$z_{in} = 1.2 \text{ k}\Omega$ $I_{nom} = 10 \text{ mA}$ (8 to 20 mA) $V_{min} = 15 \text{ Vdc}$ $V_{max} = 25 \text{ V}$
OPTOISOLATED OUTPUTS Drive OK/ Motor OK	$z_{out} = 1.2 \text{ k}\Omega$ $I_{max} = 20 \text{ mA}$ $V_{nom} < 25 \text{ Vdc}$
Analog tacho outputs 1,2,3	$z_{out} = 100 \text{ }\Omega$ $I_{max} = 5 \text{ mA}$ Range: see ET command Gain error = $\pm 10\%$ over production spread Max linearity error: $\pm 2\%$ over full range
Analog Out1 Analog Out2	$z_{out} = 100 \text{ }\Omega$ $I_{max} = 10 \text{ mA}$ Full scale = $\pm 10 \text{ V}$
Velocity differential Reference Signals 1,2,3	$z_{in} > 20 \text{ k}\Omega$ Full scale = $\pm 10 \text{ V}$
Simulated Encoder differential output signals	$z_{out} = 100 \text{ }\Omega$ Full scale = 7V (RS422/RS485 compatible)

## 2.16 Serial Link Connection

*REMARK: for the first installation it is strongly recommended to use either the optional keypad or the DBTALK communication program.*

### 2.16.1 Optional Keypad

The keypad is an optional accessory product which can be used for drive setup and monitoring. The keypad must be connected to J10 connector of Power Supply. If problems occur when attempting to communicate, the keypad is most likely set incorrectly. To start the setup procedure press <CTRL>, then <CR>. For each parameter the current setting is displayed, together with a question asking if you want to change it. The correct setting is:

```
BAUD = 9600
WORD = 8D+E+1 STOP
BLOCK MODE
SINGLE LINE MODE
FLASHING OFF
KEY REPEAT ON SLOW
```

Be sure to save at the end of the procedure by pressing <Y> when the display shows: "Make changes permanent Y/N".

### 2.16.2 Connection to Personal Computer

#### 2.16.2.1 RS232/RS485 Full-duplex Converter

The RS422 interface wiring is based on one-to-one, no multidrop, principle. Four wires are used. With RS422, you can transmit and receive data simultaneously (full-duplex). The RS485 half-duplex uses only two wires. It allows multidrop communication. With RS485 half-duplex, you cannot transmit and receive simultaneously. We supports RS485 full-duplex with four wires (RS422 compatible). Up to 99 DBM and up to 15 DBS drives can be connected in multidrop configuration.

#### • **RS232/485 CONVERTER KIT**

This very small external converter provides a full-duplex interface between PC and DBM. The converter must be fit directly into a COM port (RS232) of a PC. This way the link becomes purely RS485, less susceptible to noise and able to transmit over much longer distances than RS232.

The kit includes:

- the converter to fit into DB25-S connector of the PC (COM port)  
The DTE/DCE switch of the converter must be set to DCE (Data Communications Equipment)
- a DB25 to DB9 interface (to be used if the PC COM port is DB9-S)
- a 2 m cable to connect the converter to DBM J10 connector



- An optoisolated PC board RS 485 full-duplex driver can also be used. The following wiring must be used.

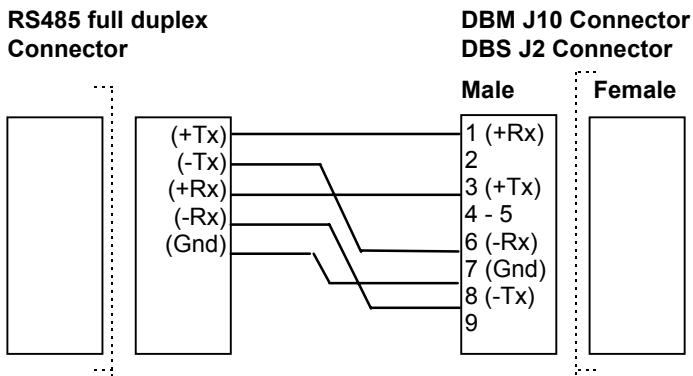

### 2.16.2.2 DBTALK Program

- **PC REQUIREMENTS**

- 80286, 80386, 80486 microprocessor or better
- Hard disk and one diskette drive. You need 2 Mbytes of disk space and 512 kbytes of RAM
- CGA, EGA, VGA, MCGA graphics card (color VGA recommended)
- MS-DOS 6.2 or later
- ANSI.SYS in CONFIG.SYS

- **DBTALK PROGRAM**

The DBTALK program is available on floppy disk

- **INSTALL PROGRAM**

- Insert diskette into drive A or drive B
  - Type <a:install> (or <b:install>)
- The installation program will create the Directory C:\DBTALK, will copy all the files in this new directory and will start the program

- **START PROGRAM** (after the first installation)

- Type <cd dbtalk>
- Type <start>

- **MOVE IN THE PROGRAM**

	Start the selected procedure
	Select the field
Space	Reread parameters
	Move up/down
	Go to previous/next screen
Esc	Exit/Go to previous menu

- **SELECT PROGRAM**

- ⇒ DBM linker
- ⇒ DBS linker
- ⇒ PDBS Linker (see PDBS Application Manual)
- ⇒ Setup

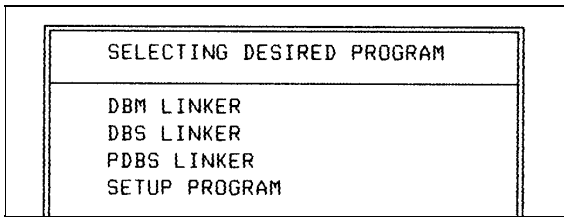

- **SETUP** to choose

- ⇒ Language: Italian or English
- ⇒ Serial link : COM1 or COM2

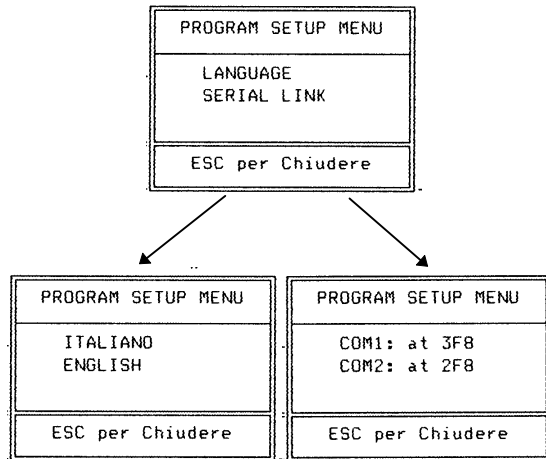

- **UTILITY** to

- ⇒ Scan Baud rates

ADDRESS AND BAUDRATE AUTOMATIC SCANNING												
	C	BAUD	C	BAUD	C	BAUD	C	BAUD	C	BAUD	C	BAUD
M	1	9600	18		35		52		69		86	
-	2	9600	19		36		53		70		87	
	3	9600	20		37		54		71		88	
E	4		21		38		55		72		89	

- ⇒ Scan Faults

06-17-1996		AUTOMATIC FAULT SCANNING				20:06:40	
C	FAULT DESCRIPTION				C	FAULT DESCRIPTION	
	A01	FA000000	P00000	MA000	B000		
	A02	FA000000	P00000	MA000	B000		
	A03	FA000000	P00000	MA000	B000		

⇒ Restore/store Personality Card parameters

To save the actual parameter set, select STORAGE PARAMETER, select the file (e.g. ST1), press <TAB> to change the description and press <CR>

SETUP PERSONALITY CARD	FILE SETUP SELECTION
COM : FUNCTION SELECTION	POLI=6/6 RPM=3000 SE=1024
RESTORE PARAMETER	DF1 ST1 ST5 ST9 ST13 ST17
STORAGE PARAMETER	DF2 ST2 ST6 ST10 ST14 ST18
	DF3 ST3 ST7 ST11 ST15 ST19
	DF4 ST4 ST8 ST12 ST16 ST20

⇒ Set Baud rates

⇒ Start the Autophasing procedure

⇒ Set the "Adjustment of Torque/Speed curve" procedure

• **MANUAL** to

⇒ See/Reset Faults

If the fault condition is not present anymore, the fault will be reset automatically. To reset the fault on the screen, go to the next screen with the arrow keys

Send Command		1st ADDRESS[01]]
Driver Answer		
Communication Status	-- REGULAR --	SET ADDRESS [01]
POWER SUPPLY FAULT		SELECTED AXIS FAULT
OVERTEMPERATURE		MOTOR OVERTEMPERATURE
BRAKING CIRCUIT		RESOLVER DISCONNECTED
220Vac INPUT		AXIS SHORT CIRCUIT
PERSONALITY CARD		NOT CONGRUENT PHASE
		VELOCITY ERROR
		I2T Protection
(A) MODULE FAULT (DBM)		(B) MODULE FAULT (EBM)
OVERTEMPERATURE		OVERTEMPERATURE
BUS BAR VOLTAGE		BUS BAR VOLTAGE
AUX VOLTAGE Ref. - AT		AUX VOLTAGE Ref. - AT

⇒ Display the Status

Send Command Driver Answer Communication Status	-- REGULAR --	1st ADDRESS[01] SET ADDRESS [01]																								
<table border="1"> <tr><th colspan="2">MODULE STATUS</th></tr> <tr><td>REFERENCE ENABLE</td><td>ON</td></tr> <tr><td>Opto DRIVE OK OUTPUT</td><td>OFF</td></tr> <tr><td>PRIORITY (G2 DROP)</td><td>KEYBOARD</td></tr> <tr><td>EXPANSION (EBM)</td><td>ADVISED</td></tr> </table>	MODULE STATUS		REFERENCE ENABLE	ON	Opto DRIVE OK OUTPUT	OFF	PRIORITY (G2 DROP)	KEYBOARD	EXPANSION (EBM)	ADVISED	<table border="1"> <tr><th>SELECTED AXIS STATUS</th><th>ENABLED</th></tr> <tr><td>DRIVE ENABLE</td><td>ON</td></tr> <tr><td>TORQUE ENABLE</td><td>OFF</td></tr> <tr><td>REFERENCES</td><td>DIGITAL</td></tr> <tr><td>ILIMIT</td><td>DIGITAL</td></tr> <tr><td>SYSTEM CONTROL</td><td>VELOCITY</td></tr> <tr><td>ROTATION</td><td>C.CLOCKWISE</td></tr> </table>	SELECTED AXIS STATUS	ENABLED	DRIVE ENABLE	ON	TORQUE ENABLE	OFF	REFERENCES	DIGITAL	ILIMIT	DIGITAL	SYSTEM CONTROL	VELOCITY	ROTATION	C.CLOCKWISE	
MODULE STATUS																										
REFERENCE ENABLE	ON																									
Opto DRIVE OK OUTPUT	OFF																									
PRIORITY (G2 DROP)	KEYBOARD																									
EXPANSION (EBM)	ADVISED																									
SELECTED AXIS STATUS	ENABLED																									
DRIVE ENABLE	ON																									
TORQUE ENABLE	OFF																									
REFERENCES	DIGITAL																									
ILIMIT	DIGITAL																									
SYSTEM CONTROL	VELOCITY																									
ROTATION	C.CLOCKWISE																									
<table border="1"> <tr><th colspan="2">SPARE OUTPUT</th></tr> <tr><td>ANALOG OUT 1</td><td>EV AXIS 2</td></tr> <tr><td>ANALOG OUT 2</td><td>IOUT AXIS 3</td></tr> </table>	SPARE OUTPUT		ANALOG OUT 1	EV AXIS 2	ANALOG OUT 2	IOUT AXIS 3	<table border="1"> <tr><th colspan="2">(B) MODULE FAULT (EBM)</th></tr> <tr><td>OVERTEMPERATURE</td><td></td></tr> <tr><td>BUS BAR VOLTAGE</td><td></td></tr> <tr><td>AUX VOLTAGE Ref. - AT</td><td></td></tr> </table>	(B) MODULE FAULT (EBM)		OVERTEMPERATURE		BUS BAR VOLTAGE		AUX VOLTAGE Ref. - AT												
SPARE OUTPUT																										
ANALOG OUT 1	EV AXIS 2																									
ANALOG OUT 2	IOUT AXIS 3																									
(B) MODULE FAULT (EBM)																										
OVERTEMPERATURE																										
BUS BAR VOLTAGE																										
AUX VOLTAGE Ref. - AT																										

⇒ See/Change parameters

To change one parameter type the command string on the PC keyboard. Example: 3VE3000

Send Command Driver Answer Communication Status	3VE3000 -- REGULAR --	1st ADDRESS[01] SET ADDRESS [03]																																																																										
<table border="1"> <tr><th colspan="2">MODULE S</th></tr> <tr><td>REFERENCE EN</td><td>0</td></tr> <tr><td>Opto DRIVE 0</td><td>0</td></tr> <tr><td>PRIORITY (G2</td><td>0</td></tr> <tr><td>EXPANSION (</td><td>0</td></tr> </table>	MODULE S		REFERENCE EN	0	Opto DRIVE 0	0	PRIORITY (G2	0	EXPANSION (	0	<table border="1"> <tr><th>COM</th><th></th></tr> <tr><td>NP</td><td>6</td></tr> <tr><td>PR</td><td>1</td></tr> <tr><td>RS</td><td>15168</td></tr> <tr><td>CP</td><td>1742</td></tr> <tr><td>VE</td><td>0</td></tr> <tr><td>VS</td><td>1</td></tr> <tr><td>DF</td><td>0</td></tr> </table>	COM		NP	6	PR	1	RS	15168	CP	1742	VE	0	VS	1	DF	0	<table border="1"> <tr><th>COM</th><th></th></tr> <tr><td>AC</td><td>0</td></tr> <tr><td>DE</td><td>0</td></tr> <tr><td>EV</td><td>0</td></tr> <tr><td>OV</td><td>128</td></tr> <tr><td>OC</td><td>128</td></tr> <tr><td>CU</td><td>128</td></tr> <tr><td>CV</td><td>128</td></tr> </table>	COM		AC	0	DE	0	EV	0	OV	128	OC	128	CU	128	CV	128	<table border="1"> <tr><th>COM</th><th></th></tr> <tr><td>IT</td><td>7</td></tr> <tr><td>PC</td><td>50</td></tr> <tr><td>IL</td><td>100</td></tr> <tr><td>MV</td><td>3000</td></tr> <tr><td>MR</td><td>10.0</td></tr> <tr><td>KI</td><td>20</td></tr> <tr><td>KP</td><td>80</td></tr> </table>	COM		IT	7	PC	50	IL	100	MV	3000	MR	10.0	KI	20	KP	80	<table border="1"> <tr><th>COM</th><th></th></tr> <tr><td>SE</td><td>1024</td></tr> <tr><td>RX</td><td>16</td></tr> <tr><td>RN</td><td>12</td></tr> <tr><td>ET</td><td>80</td></tr> <tr><td>ES</td><td>16</td></tr> <tr><td>BR</td><td>9600</td></tr> </table>	COM		SE	1024	RX	16	RN	12	ET	80	ES	16	BR	9600
MODULE S																																																																												
REFERENCE EN	0																																																																											
Opto DRIVE 0	0																																																																											
PRIORITY (G2	0																																																																											
EXPANSION (	0																																																																											
COM																																																																												
NP	6																																																																											
PR	1																																																																											
RS	15168																																																																											
CP	1742																																																																											
VE	0																																																																											
VS	1																																																																											
DF	0																																																																											
COM																																																																												
AC	0																																																																											
DE	0																																																																											
EV	0																																																																											
OV	128																																																																											
OC	128																																																																											
CU	128																																																																											
CV	128																																																																											
COM																																																																												
IT	7																																																																											
PC	50																																																																											
IL	100																																																																											
MV	3000																																																																											
MR	10.0																																																																											
KI	20																																																																											
KP	80																																																																											
COM																																																																												
SE	1024																																																																											
RX	16																																																																											
RN	12																																																																											
ET	80																																																																											
ES	16																																																																											
BR	9600																																																																											

**Fig.2.16 - STARTING SEQUENCE - TIMING CHART**

**1. PS-Standard and PS-6M:  $t_1 = 8$  to  $10$  s,  $t_2 \geq 1$  s,  $t_3 \geq 20$  ms,  $t_4 = 3$  s,  $t_5 \geq 0.5$  s**

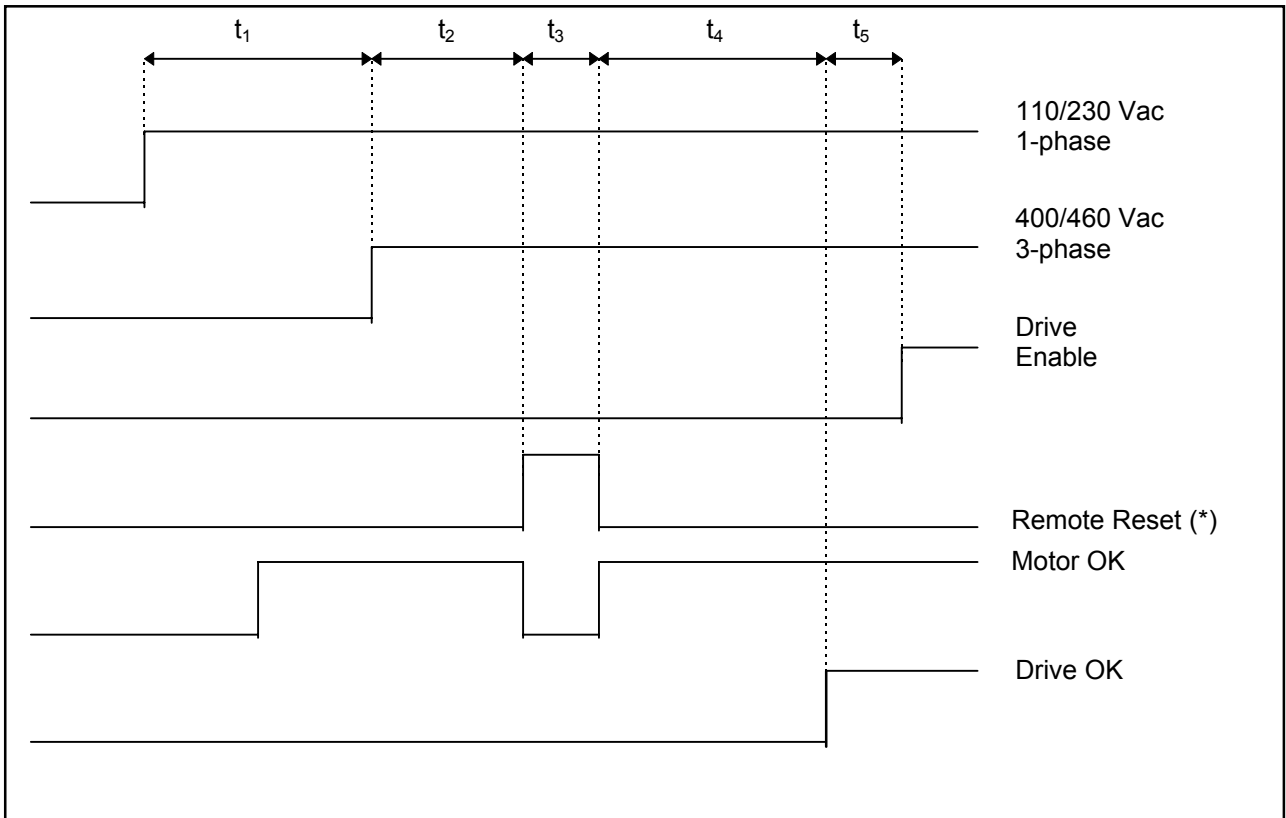

**2. PS-Standalone and PS-120:  $t_1 \geq 20$  ms,  $t_2 \geq 1$  s,  $t_3 \geq 20$  ms,  $t_4 = 3$  s,  $t_5 \geq 0.5$  s**

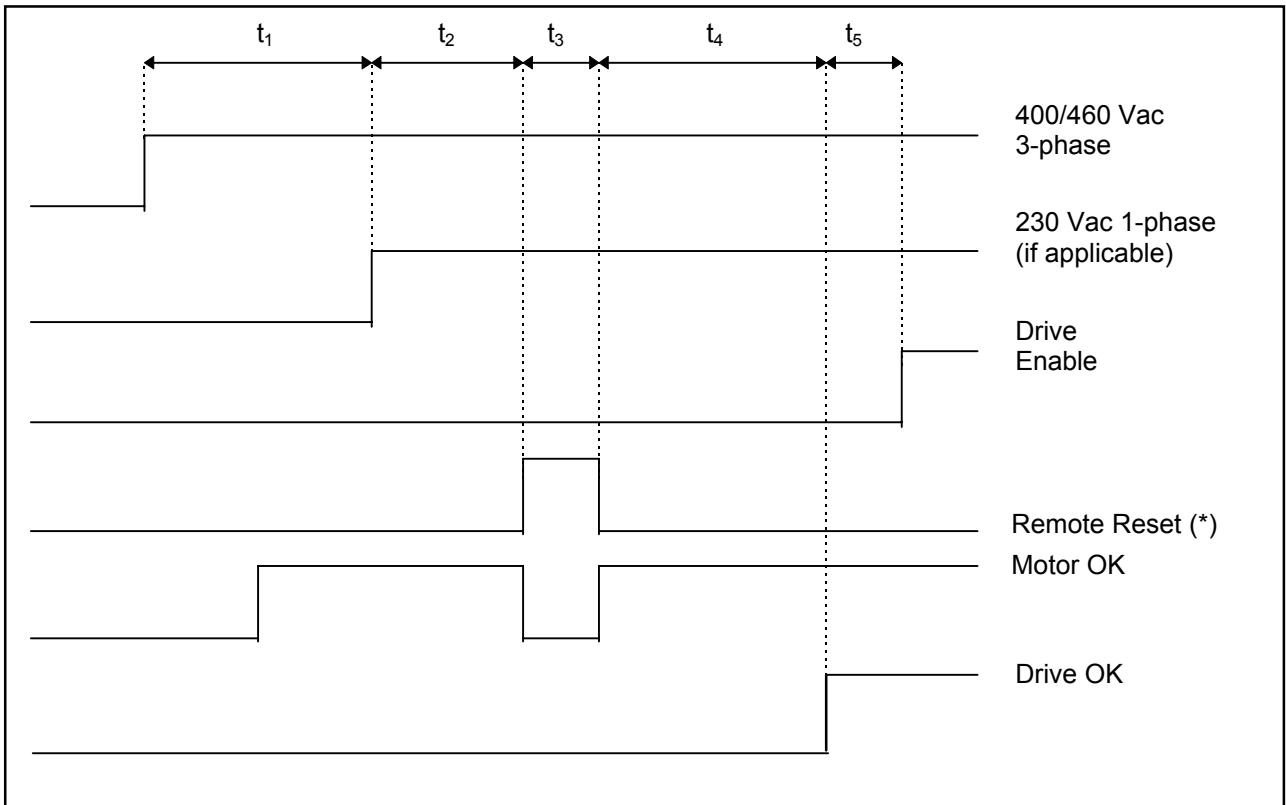

**(\*) CAUTION:** the Remote Reset must be a single nonrepetitive signal. Otherwise it must be filtered with 500 Hz cutoff frequency.

**3. PS-U:  $t_1 = 6\text{ s}$ ,  $t_2 = 2\text{ to }4\text{ s}$ ,  $t_3 = 4\text{ s}$**

**WARNING:** make sure that the AUX EXT CONTACT (pos.5 and 6 of J12 connector) is connected to 24Vdc before starting.

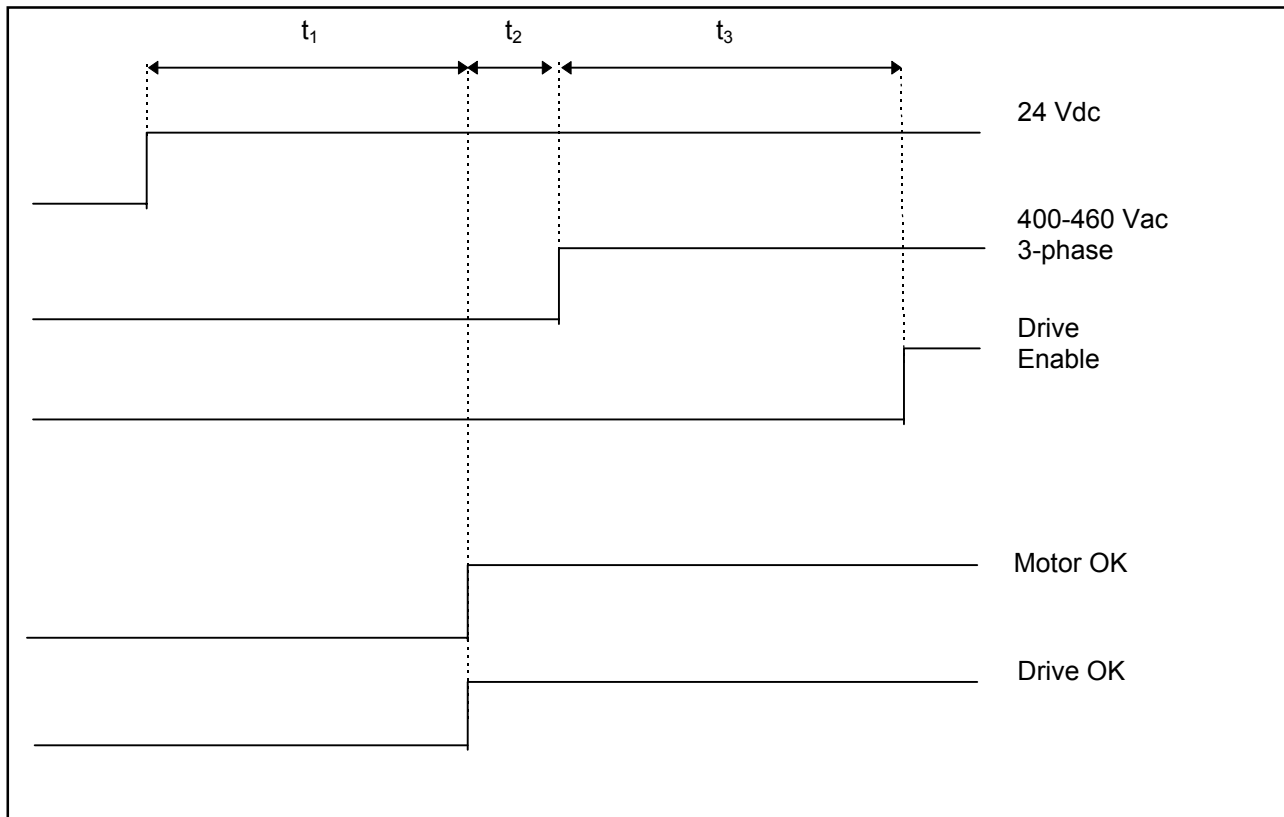

## 2.17 Starting Sequence

The starting sequence depends on the type of Power Supply. See Fig.2.16 for the Timing-chart.

\* PS-Standalone and PS-120

1. Apply the 400Vac (or 460Vac) three phase power voltage
2. Apply (if applicable) the 230 Vac single phase auxiliary voltage via dedicated transformer

\* PS-Standard and PS-6M

1. Apply the 230 Vac (or 110Vac) single phase auxiliary voltage
2. Apply the 400Vac (or 460Vac) three phase power voltage

\* PS-U

1. Apply the 24 Vdc auxiliary voltage
2. Apply the 400Vac (or 460Vac) three phase power voltage

**WARNING:** *High Voltage - Discharge time approx. 6 minutes.*

- Multimodule configuration only. Disconnect the first module from the serial link and assign basic address to the second module and so on for the next modules (all the modules from factory being usually configured with address 1,2,3 if triple-axis or with address 1,2 if double-axis).

Example of basic address assignment for the 2nd module, if the first module is triple-axis:

FROM KEYPAD

```
1 SA 4 <CR>      Assign basic address 4 to the second module
4 SV <CR>        Save the address configuration
```

Note: A module programmed as "address 4" will automatically assign for the other axes the following addresses, i.e. 5 - 6 (if triple-axis) or 5 (if double-axis); and so on for the next basic addresses.

- Check if NP (pole number), MV (max velocity), MR (max reference) and other required parameters are OK for the application.
- Make a hardware reset via button on drive or via positive logic on pin 18 of J8 connector (software reset via FA command being useless for digital control card reinitialization).

### 2.17.1 Autophasing

- Check that the motor is free to rotate in both directions.
- Check that no fault condition occurs (red drive-fault leds off).
- The jumper G2 on the personality card must be open.
- Check that all module axes have analog drive enable on via positive logic and digital drive enable off.
- Send the password command for the module.
- Send the autophasing command for every axis of the module and save.

Example for a double module with axis 4 and axis 5:

FROM KEYPAD	
4 PW91 <CR>	Give the password for the 2nd module
PASSWORD ON	The correct answer is displayed
<CR>	Only for optional keypad.
4 AP <CR>	Allow axis 4 autophasing.
AUTOPHASING IN PROGRESS	
AXIS PHASED	
5 AP <CR>	Allow axis 5 autophasing.
AUTOPHASING IN PROGRESS	
AXIS PHASED	
4 SV <CR>	Save module 4 phasing.

- Repeat the password and autophasing procedures for subsequent modules (if applicable).
- Make a hardware reset via button on drive or via positive logic on pin 18 of J8 connector.

### 2.17.2 Wiring Check

Axes being phased it is possible to check the wiring by rotating the motor via its digital reference.

- Enable analog drive-enable and reference-enable via positive logic.
- Check that G2 is open for keypad priority.
- Send to every axis the ON command (to enable digital drive-enable) , the VE command (for CW slow rotation), the VE- command (for CCW slow rotation), the OF command (to disable the digital drive-enable).

Example of checking axis 5 rotation:

FROM KEYPAD	
5 ON <CR>	Enable digital drive-enable for axis 5
○	Drive enable led will be on
5 VE 50 <CR>	Set CW rotation at 50 rpm
5 VE-50 <CR>	Set CCW rotation at 50 rpm
5 OF <CR>	Disable digital drive-enable for axis 5
●	Drive enable led will be off

### 2.17.3 CNC Priority

With CNC, the following procedures must be followed.

#### 2.17.3.1 Setting Of Analog References

To set the modules to use the analog references from the CNC, it is necessary to enter the password, to send the AR command to every axis and to save. ST command can be sent to check if the commands have been accepted.



Note that:

- AR command can be sent via global address (\*).
- If there are two or more modules, PW (password) and SV (save) commands can be sent to each module.

Example of enabling all the analog references for two modules with axes 1,2,3 and 4,5:

FROM KEYPAD	
1 PW91 <CR>	Give the password for the 1st module
PASSWORD ON	The correct answer is displayed
4 PW91 <CR>	Give the password for the 2nd module
PASSWORD ON	The correct answer is displayed
* AR <CR>	Enable analog reference for all axes
1 SV <CR>	Save the configuration for the 1st module
4 SV <CR>	Save the configuration for the 2nd module
1 ST <CR>	Ask the status for axis 1
A1 ST__ E__ I_0__	Displays the axis 1 status. Check the 0 in the 2nd bit after I
...	Repeat ST command and check other axes

### 2.17.3.2 Drive Enable With CNC Priority

To give the priority for enabling and disabling the drive from the CNC, it is necessary to pull out the personality card from the module, to solder G2 jumper and to pull in the card.

*REMARK: if there are more than one module, do not swap the personality cards, this will swap the module data.*

When the above procedure is completed, the CNC is the master and the keypad is the slave, as follows:

PARAMETERS MANAGED BY CNC:	drive enable, reference enable, speed references.
PARAMETERS MANAGED BY KEYPAD:	all dynamic parameters (acceleration, deceleration, KI, KP, etc.), status and fault.

### 2.17.4 Velocity Offset

If it is necessary you can adjust the analog velocity offset by providing 0 analog speed reference and setting VO command for an automatic adjustment. A fine adjustment can be done with successive steps via OV command.

*REMARK: the adjustment of the digital velocity offset must not be used to adjust the analog velocity offset and it is reserved to setup technicians. It can be made by providing 0 digital speed reference (VE=0) and setting OC command. The opto Drive Enable must be high.*

## 2.18 - Resolver To Encoder Option

For position sensing a resolver to encoder option (simulated encoder) is available.

Encoder signals are 7V, 100  $\Omega$  impedance, as follows:

- 2 channels of square wave output with a resolution from 128 to 16384 pulses per electrical revolution. Channel B leads channel A by 90° for clockwise rotation when viewed from shaft end.
- 1 marker pulse per electrical revolution (i.e. 1\* 3 = 3 marker pulses per mechanical revolution with a 6 pole resolver).
- complementary outputs  $\bar{A}$ ,  $\bar{B}$  and  $\bar{C}$ .

**Fig. 2.17 - Simulated Encoder (CW Rotation When Viewed From Shaft End)**

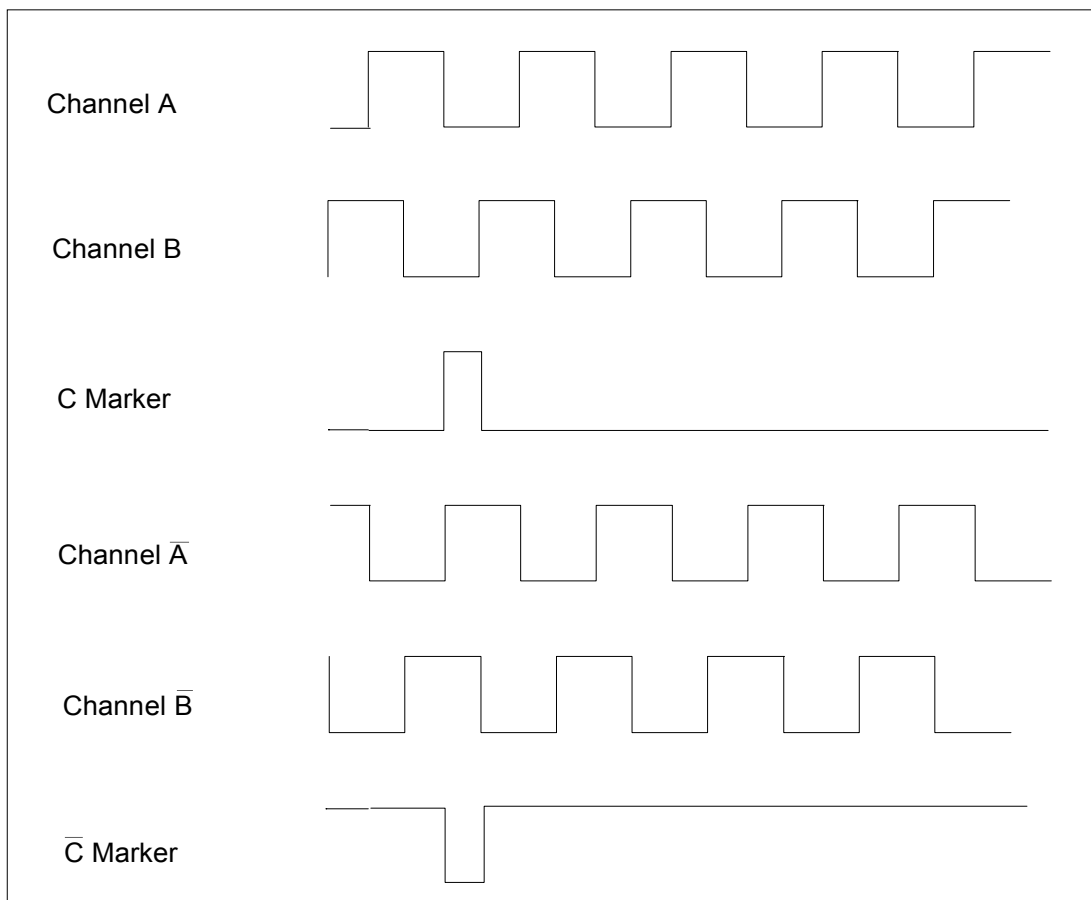

Note: to make C Marker high when Channel A and Channel B are high (like Siemens), swap Channel A with Channel  $\bar{A}$  and Channel B with Channel  $\bar{B}$ .

### 2.18.1 Setup For Encoder Resolution

The number of pulses per electrical revolution of simulated encoder can be set via SE software command.

Example of a setup for axis 1.

FROM KEYPAD	
1 PW91 <CR>	Give the standard password for axis 1
PASSWORD ON	The correct answer is displayed
<CR>	Only for optional keypad
1 SE 4096 <CR>	Set 4096 ppr to axis 1
1 SE <CR>	Ask the number of ppr for axis 1
A01 SIMULATED ENCODER = 4096	
1 SV <CR>	Save

*REMARK: the maximum number of pulses per electrical revolution depends on the R/D resolution. See the following Table.*

The width of C marker can be A (360°), A/2 (180°) or A/4 (90°); it must be specified in the order. This parameter does not depend on the software commands.

Note: to obtain the resolution per mechanical revolution it is necessary to multiply the pole pairs by the electrical resolution.

Example: if a FAS T motor with 6 pole resolver is used, 1024 pulses per electrical revolution mean  $1024 * 3 = 3072$  pulses per mechanical revolution.

### 2.18.2 R/D Resolution

The resolution of Resolver to Digital converter will automatically be switched according to actual speed for optimum system performance between minimum (see RN command in the User's Manual) and maximum resolution (see RX command). The speed range of R/D resolution is included in the following table.

**Tab. 2.32 - Max speed and max ppr versus R/D resolution**

	Resolution (bit)			
	10	12	14	16
Max number of pulses per electrical revolution	256	1024	4096	16384
Max speed with 2 pole resolver (rpm)	24000	12000	3510	877
Max speed with 6 pole resolver (rpm)	8000	4600	1170	292
Max speed with 8 pole resolver (rpm)	6000	3510	877	219

## 2.19 Mechanical Brake

FAS series servomotors have as option a 24 Vdc electromagnetic safety brake.

**CAUTION:** *safety brake must be clamped and released with motor at standstill. Premature failure of the brake will result if brake is used for dynamic stopping of the motor.*

The release of the brake (from 0V to +24V) and the clamp (from +24V to 0V) must follow the sequence in Fig. 2.18.

**FIG. 2.18 - BRAKING SEQUENCE, TIMING CHART**

Note:  $T1 \geq 200$  ms,  $T2 =$  application dependent,  $T3 = 100$  ms,  $T4 \geq 200$  ms

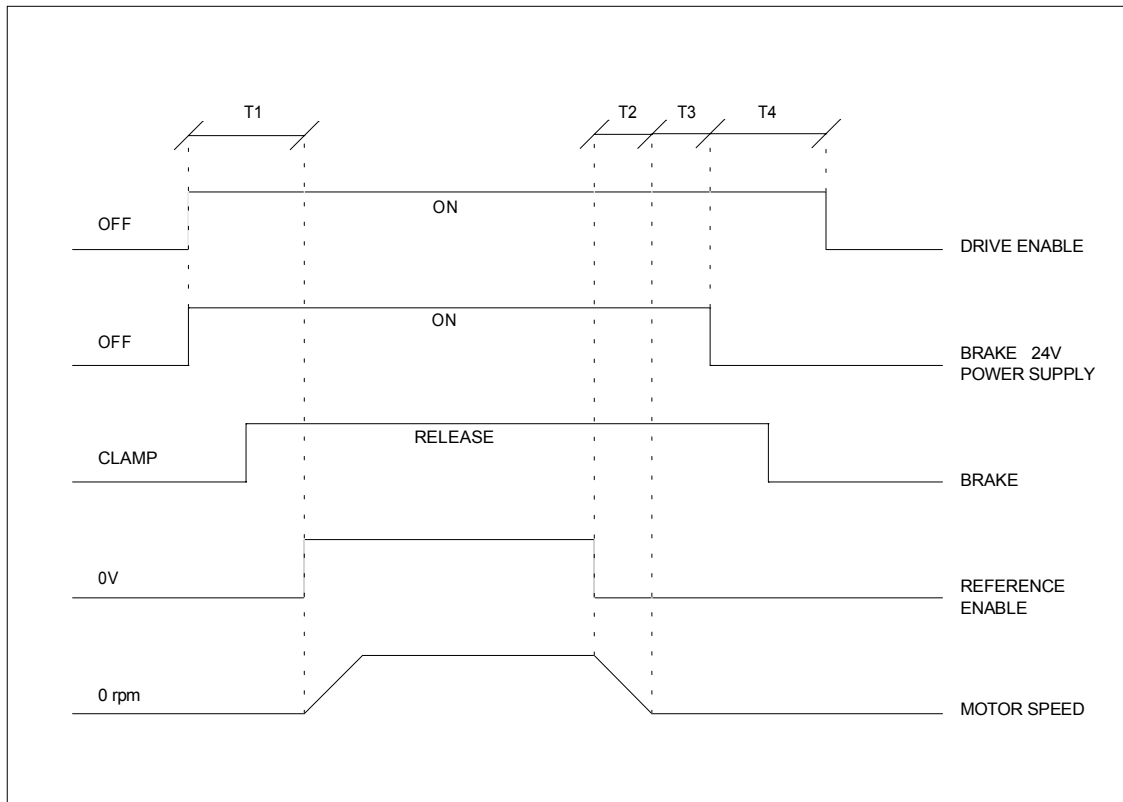

## 2.20 Module Replacement

Once DBM module to be replaced has been identified, it is necessary to follow this procedure:

- Disconnect the power.
- Remove the Bus Bars (+HV, -HV and GND) and disconnect all connectors and flat cables.
- Unscrew the anchor screw on the top of the module and remove the module.  
Remove the Personality Card, at the left of J1 connector, by loosening the two screws. After removing the card, disconnect the flat cable.

*REMARK: on the personality card a EEPROM is mounted. All dynamic parameters (dynamic settings, autophasing, analog interfaces, ...) are stored in this EEPROM after every reset.*

*In case of module replacement, it is recommended to save all parameters with the save (SV) command before removing the Personality Card ready for installation in the replacement module. This retains and transfers all the previous module information's.*

Remove the Personality Card from the new module and replace with the old one.

- Mount the new module and tighten the anchor screw at the top.
- Reassemble the Bus Bars, all the connectors and flat cables.
- Check all connections.
- Enable the auxiliary voltage and check by keypad or PC all application dependent parameters. In particular: pole number, max velocity, max reference voltage, llimit, internal ramp generator.

**This page intentionally blank**

# SECTION 3 - ELECTROMAGNETIC COMPATIBILITY (EMC)

## 3.1 European Directive (89/336/EEC)

Compliance with the European Directive 89/336/EEC is required for all electric and electronic products brought onto the European market after December 31st, 1995.

DBM04 drives with FASTACT motors meet the following EMC product standard related to the Directive:

EN 61800-3 (1996) and EN 61800-3/A11 (2000): "Adjustable speed electrical power drive systems. Part 3: EMC product standard including specific test methods".

Second environment (industrial) compatibility levels.

*Remark: equipments not intended to be used on a low-voltage public network which supplies domestic premises. May cause radio frequency interference.*

Tests have been made in an independent test house.

The installer of the drive is responsible for ensuring compliance with the EMC regulations that apply where the drive is to be used. We recommend filtering as per par.3.2 and wiring, grounding and screening as per par.3.3 and 3.4.

## 3.2 Filtering

The following filters are recommended.

### 3.2.1 Filter Types

Code	Trade-mark	Rated Current [A] at 50°C (40°C)	Max Voltage [Vac] at 50°C	Drive type
AT6008	Schaffner FN 250-6/07	(6)	250	DBM04 PS-Standard, PS-Standalone, PS-6M, PS-120 (Aux Pwr)
-	Schaffner FN 250-12/07	(12)	250	DBM04 PS-U (Aux Pwr)
AT6009	Schaffner FN 258-7/07	7 (8.4)	3 x 480	
AT6010	Schaffner FN 258-16/07	16 (19.2)	3 x 480	
AT6011	Schaffner FN 258-30/07	30 (36)	3 x 480	
AT6012	Schaffner FN 258-42/07	42 (50.4)	3 x 480	
AT6013	Schaffner FN 258-55/07	55 (66)	3 x 480	DBM04 PS Standard, PS-6M, PS-U and PS-Standalone
AT6014	Schaffner FN 258-75/34	75 (85)	3 x 480	
AT6015	Schaffner FN 258-100/35	100 (120)	3 x 480	DBM04 PS120

### 3.2.2 Filter Sizing

The filter/drive coupling in the previous table is a standard coupling. The filter can be undersized according to the rms input current of the actual application. This should be done not only because, as a matter of fact, undersizing the filter means less money, but because the undersized filter provides better performance to EMC.

Example:

- **DBM04 PS-Standard + DBM 04 6-6-6 + DBM 04 6-6-6** and contemporaneity factor of 0.8.

For this application it is not necessary to use the 55A filter of the table.

The reference current is  $I_{in} = 6 * 6 * 0.8 = 28.8 \text{ A}$

A 30A filter (FN 258-30/7) can safely be used.

### 3.2.3 Filter Dimensions

Code	Trade-mark	Dimensions [mm]							Weight [kg]
		L1	L2	L3	L4	L5	L6	I7	
AT6008	Schaffner FN 250-6/07*	85	75	54	0	65	30	300	0.24
	Schaffner FN 250-12/07*	85	75	54	0	65	40	300	0.31
AT6009	Schaffner FN 258-7/07	255	240	50	25	225±0.8	126±0.8	300	1.1
AT6010	Schaffner FN 258-16/07	305	290	55	30	275±0.8	142±0.8	300	1.7
AT6011	Schaffner FN 258-30/07	335	320	60	35	305	150	400	1.8
AT6012	Schaffner FN 258-42/07	329	314	70	45	300	185	500	2.8
AT6013	Schaffner FN 258-55/07	329	314	80	55	300	185	500	3.1
AT6014	Schaffner FN 258-75/34	329	314	80	55	300	220	terminal block	4
AT6015	Schaffner FN 258-100/35	379±1.5	364	90±0.8	65	350±1.2	220±1.5	terminal block	5.5

\*= the FN250-6/07 and 12/07 filters have wiring leads (length=300mm) at both sides.

#### TOP VIEW

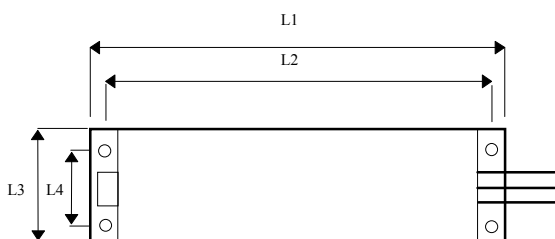

#### SIDE VIEW

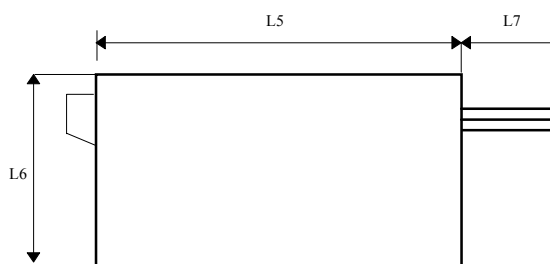



### 3.2.4 Filter Installation

- The filter must be mounted on the same panel as the drive.

**CAUTION:** leave a clear space of at least 60mm around the filter for air circulation when the cabinet does not have forced ventilation.

- The filter must be connected as close as possible to the drive input. If the separation between filter and drive exceeds around 30 cm (1 ft.) then a flat cable should be used for the RF connection between filter and drive

**REMARK:** when mounting the drive and the filter to the panel, it is essential that any paint or other covering material be removed before mounting the drive and the filter.

- The maximum torque of mounting screws is as follows:

FILTER	Max torque
FN 250 - 6/07	0.8 Nm
FN 250 - 12/07	0.8 Nm
FN 258 - 7/07	0.8 Nm
FN 258 - 16/07	0.8 Nm
FN 258 - 30/07	1.8 Nm
FN 258 - 42/07	1.8 Nm
FN 258 - 55/07	3.0 Nm
FN 258 - 75/34	3.0 Nm
FN 258 - 100/35	4.0 Nm

- The filter can produce high leakage currents (see Data Sheets by Schaffner)

- The capacitors within the filters have discharge resistors.

**CAUTION:** the filter must be connected to ground before connecting the supply

**WARNING:** High Voltage - Discharge time approx. 10 seconds

- The single phase filter can be installed on the left shoulder of the fan housing (Power Supply side), as in the following figure:

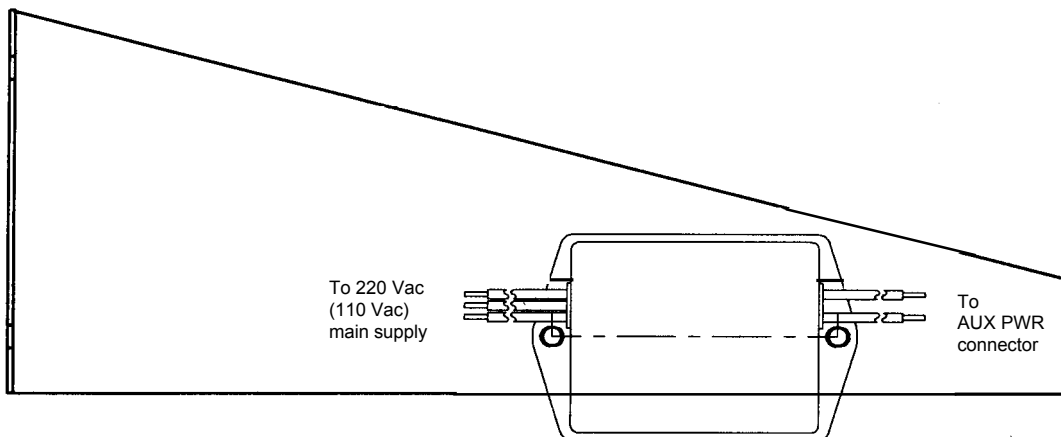

### 3.3 Wiring And Grounding

All the following cables must be shielded, with 85% minimum shielding coverage:

- power motor cable (see Fig.3.1 and 3.2)

NOTES: if a power terminal board is used at motor side, the shield must be RF connected to a metallic PG gland.

- connectors at motor side can have a threaded clamp. Cable shield must be grounded in the same way as in Fig.3.2.

- resolver cable (see Fig.2.11 and Fig.3.2 motor side)

**Fig. 3.1 - Grounding Of Shield To Motor Connector At Drive Side**

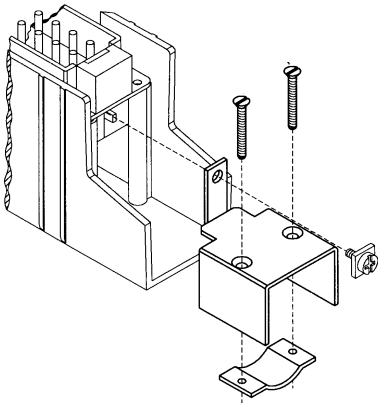

- recovery resistor cable.

**CAUTION:** the recovery resistor cable provided in kit is only for test purposes and not EMC compliant.

- Reference, Enable and OK cable
- RS485 cable (flat cable between modules excluded)
- simulated encoder cable (if applicable)

The shields of the cables must be connected at both ends to the proper housing via full circumferential bond to metallic connectors or hose clamps.

**Fig. 3.2 - Grounding Of Shield To Connectors At Motor Side**

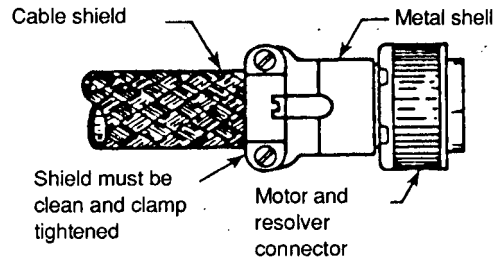

In case of Sub-D connector, cable shield must be grounded to the metallic hood.

When there is not connector at drive side, a kit with stand-off, screws and hose clamps is provided.

The shield of the cable must be uncovered from insulation coating and RF connected to the stand-off through the hose clamp, as in Fig.3.3.

**Fig. 3.3 - Grounding Of Shield Without Connector**

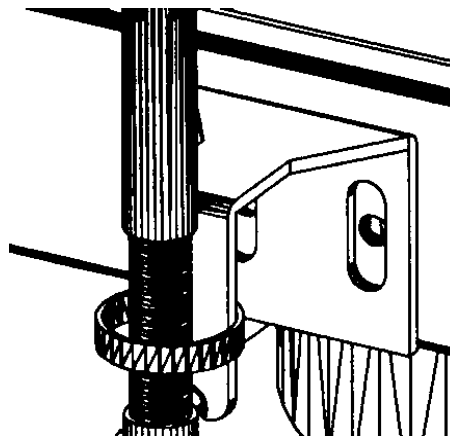

**Fig. 3.4 - Cable Grounding At Drive Side**

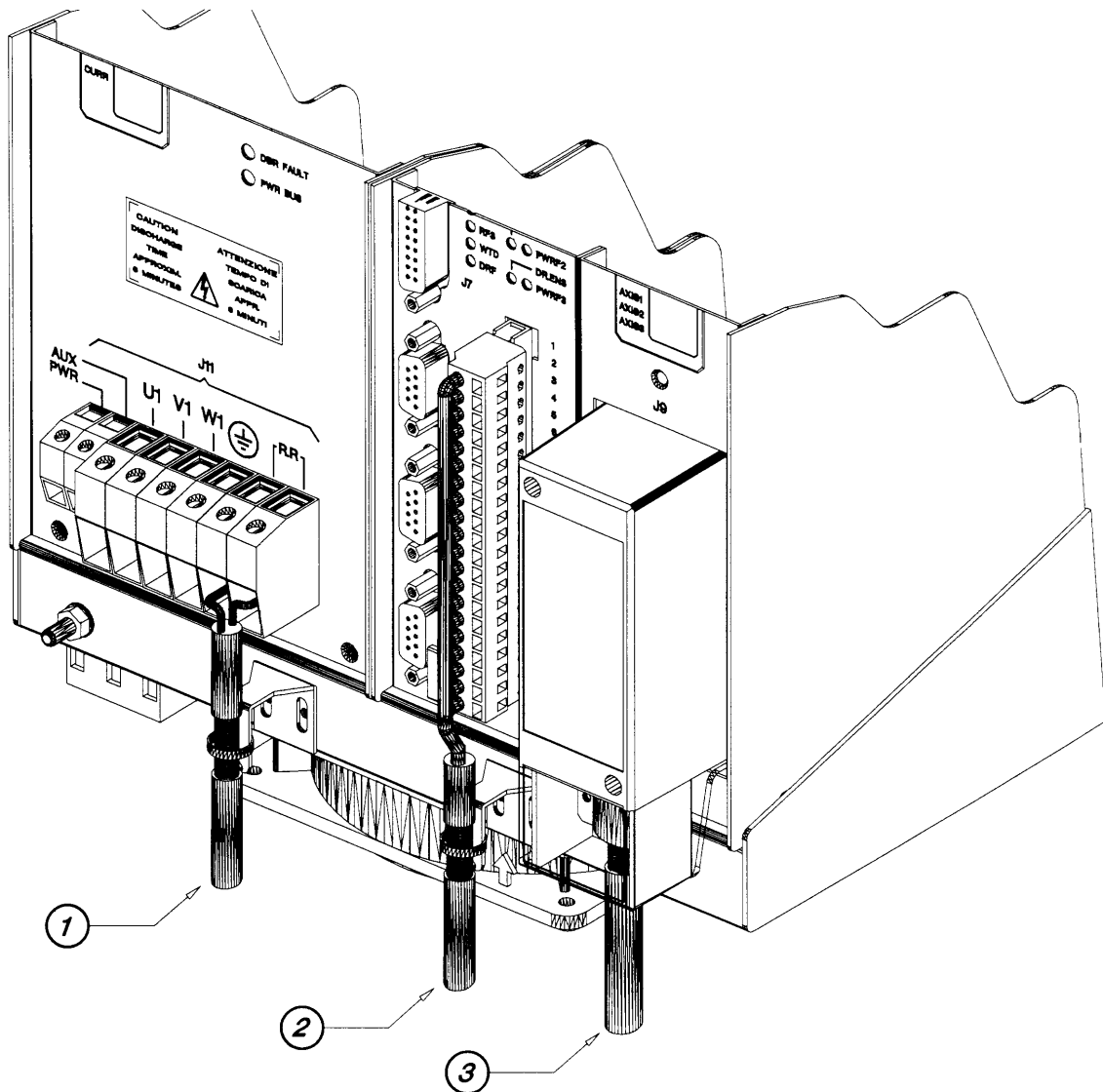

- 1 = Recovery resistor cable**
- 2 = Reference, Enable, OK cable**
- 3 = Motor power cable**

**Sub-D and unshielded cables not shown**

It is not necessary to shield the input power wires, the bus bars, the flat cables between the modules.

**REMARKS:**

- the shields of cables inside the cabinet must be 360° clamped to the cabinet wall (see Fig. 3.5).
- "noisy" cables must be kept away from "sensitive" cables by at least 30 cm (12 in). Noisy cables include input-power wires, motor power and brake wiring. Sensitive cables include analog or digital signal cables: resolver cable; reference, enable and OK cable; RS485 serial link; simulated encoder wiring.
- where noisy cables must cross power cables, this must be done with angles as near to 90° as possible.

**Fig. 3.5 - Clamping To Cabinet**

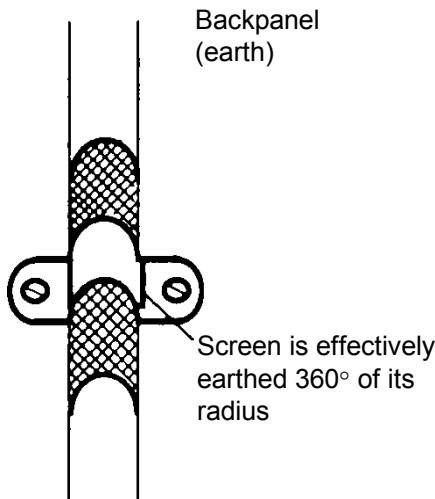

**Fig. 3.6 - Partition Penetration**

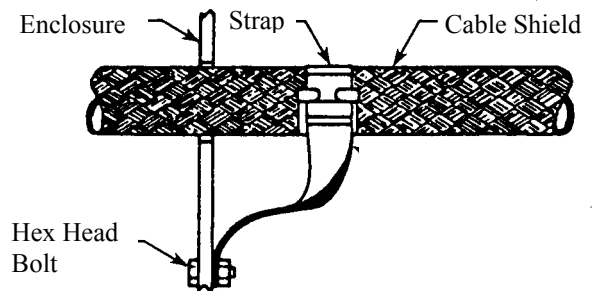

- the crossing of the cabinet should be accomplished with a low impedance connection between cable shield and enclosure. If a connector is not involved, the shortest practical lengths of connecting strap should be used (see Fig.3.6).

**3.4 Recovery Resistor/ Motor Choke**

To meet the EMC Directive, the ventilated enclosures containing dynamic braking resistors must be conductive. The cable of recovery resistor must be shielded and the shield must be 360° clamped at both sides.

In some applications (e.g. some size 3 FAS T motors) a choke in series for each motor phase has to be added. This choke must be shielded.

*REMARK: when mounting the enclosure of recovery resistor or motor choke to the panel, it is essential that any paint or other covering material be removed before mounting the enclosure of recovery resistor or motor choke.*

### 3.5 Screening

To effectively screening the system all the single screens (CNC, electronic cabinet, machine, motor housing, cables) must be connected together to effectively form one screen (see Fig.1.4).

### 3.6 Safety Aspects

Noise suppression of Motor and Drive systems involves consideration of the earthing system, and its effectiveness at high frequencies. It should not be forgotten that is the safety system too and that the safety must take priority over EMC.

To reduce the radiated emissions, the use of capacitance to earth is very effective. In fact DBM 04 drives have Y-type capacitors near the input power supply connector and Schaffner filters also include them. These capacitors conduct current from phase to earth; this can be in the order of hundreds of milliamperes.

***WARNING:*** *appropriate safety measures should be taken to ensure that this potentially dangerous current flows to earth.*

***CAUTION:*** *it is recommended to disconnect the drive and the EMC filters to carry out the AC Voltage Tests of EN 60204-1 (1997), par.19.4, in order to not damage the Y-type capacitors between phases and ground. Moreover the DC voltage dielectric test required by EN 50178 (1997), product family standard, has been carried out in factory as a routine test. The DC Insulation Resistance Tests of EN 60204-1 (1997), par.19.3, may be carried out without disconnecting the drive and the EMC filters.*

---

# MOOG

Moog Italiana S.r.l.  
Electric Division  
Via Avosso, 94  
16015 Casella (Genova) - Italy  
Phone: (+39) 010 9671  
Fax: (+39) 010 9671 280  
[www.moog.com](http://www.moog.com)