

DI2020 SERVODRIVE

On board integrated solution for decentralized machine architecture

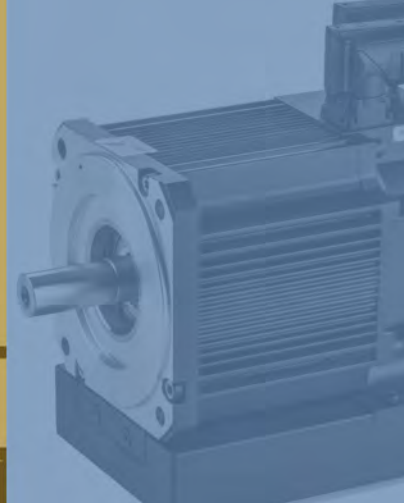
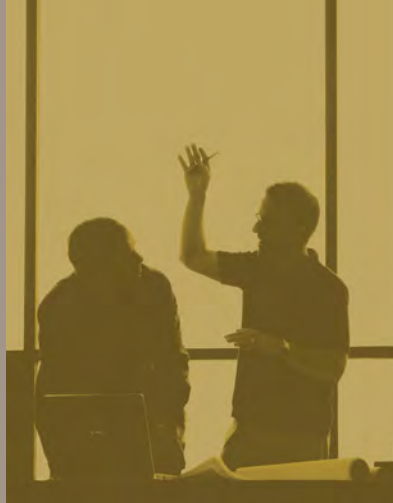

Ideal for decentralized machine architectures, the DI2020 drive integrates the servo control directly on board of the FAS H series of high efficiency brushless motors.

Following the evolution of motion control towards solutions with distributed electronics, the DI2020 allows the implementation of a decentralized architecture of the machine controls, with a consequent greater freedom of design compared to traditional centralized cabinet solutions.

This flexibility ensures substantial savings in installation times and necessary materials. With a remarkable reduction of wiring and overall dimensions of the system, it facilitates installations in environments with limited space for control cabinets.

The DI2020 finds its ideal application in machines with modular and open architecture, requiring high precision and maximum dynamic, with quick and accurate execution of movements.

The Safe Torque Off (STO) and Safe Brake Control safety functions are integrated in the standard equipment of every DI2020 model.

FEATURES AND BENEFITS

- Reduction of the number of connections and potential failures
- Reduction in component size and number
- Adjustable 90° connectors
- Design simplification
- Significant reduction of costs and installation times
- Possibility to power remotely moving sections of the machine
- Integration with the DM2020 multi-axis system allowing a reduction of the overall energy consumption of the system



APPLICATIONS

- Industrial machinery with decentralized architecture

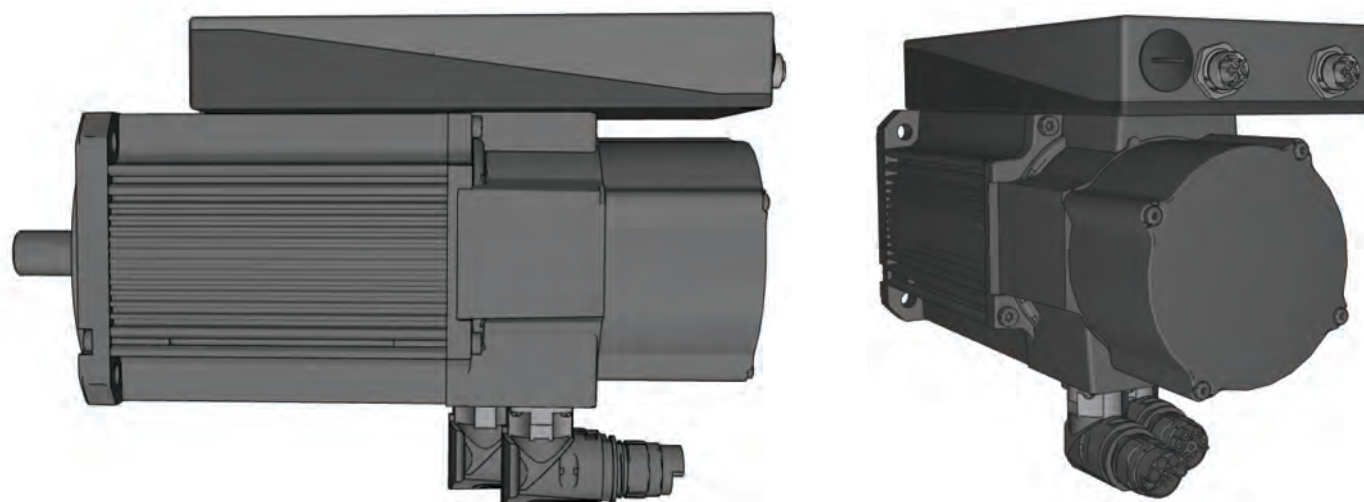

TECHNICAL DATA

Fieldbus control	EtherCAT, CANopen
Control functions	Torque, speed, position
Protection rating	IP 65
Command protocols	EtherCAT, CANopen (according to CIA 402)
PWM Frequency	4-8-16 kHz
Power supply range	282 - 810 Vdc
Environmental operating temperature	From 0°C to 40°C
Auxiliary power supply tension	24 Vdc
Machine safety	STO (Safe Torque Off) SILCL 3 SBC (Safe Brake Control) SILCL 3 PL e (*)
Set-up communication interface	EtherCAT, CANopen, USB
Certification	CE, UL (*)

**Pending approval*

Available sizes	H100-V2	H100-V4	H115-V2	H115-V4
Continuous stall torque	2 Nm	3,5 Nm	2,7 Nm	5,1 Nm
Rated torque at rated speed	1,7 Nm	2,1 Nm	1,9 Nm	2,2 Nm
Peak torque	13 Nm	20 Nm	16 Nm	22 Nm
Rated speed	3000 rpm	3000 rpm	3000 rpm	3000 rpm
Peak speed	5500 rpm	5500 rpm	4500 rpm	4500 rpm

Moog has offices around the world. For more information or the office nearest you, contact us online.

E-mail: info@moog.com

Moog is a registered trademark of Moog Inc. and its subsidiaries. All trademarks as indicated herein are the property of Moog Inc. and its subsidiaries. ©2017 Moog Inc. All rights reserved. All changes are reserved.

DI2020 Servodrive
L-LF12-E-172

For product information, visit

www.moog.com/industrial

For service information, visit

www.moogglobalsupport.com

This technical data is based on current available information and is subject to change at any time. Specifications for specific systems or applications may vary.

MOOG